

HOW TO READ THE STANDARD OF EXTERNAL TURNING TOOLS

● How this section page is organised

- ① Organised according to turning insert shape.
(Refer to the index on the next page.)

TYPE OF TOOL HOLDER indicates the first four letters of the order number, as well as cutting applications.

TITLE OF PRODUCT BY INSERT TYPE

PRODUCT SECTION

FIGURE SHOWING THE TOOLING APPLICATION uses illustrations and arrows to depict the available machining applications such as external turning, copying, facing, and chamfering together with cutting edge lead angles.

GEOMETRY

CHIP BREAKER BY CUTTING APPLICATION

EXTERNAL TURNING TOOLS

VN INSERTS TOOL HOLDERS

DVPN Facing, Copying **DOUBLE CLAMP type**

Order Number	Stock	Insert Number	Dimensions (mm)								Shim	Lock Pin	Lock Screw	Spring	Clamp	Wrench	
			H	B	LF	LH	HF	WF	MF	MF							
DVPNR/L2020K16	●●	VN A 1604	20	20	125	32	20	25	DCS/N2	LLP13	DDK113	DCS2	DC0520T	TKY15F			
DVPNR/L2525M16	●●	VN G 1604	25	25	150	32	25	32	DCS/N2	LLP13	DDK113	DCS2	DC0520T	TKY15F			

*1 Clamp Torque (N·m) : DC0520T=3.5

WN INSERTS TOOL HOLDERS

PWLN External turning, Facing **LL type**

Order Number	Stock	Insert Number	Dimensions (mm)								Shim	Lock Pin	Clamp	Clamp Screw	Wrench	
			H	B	LF	LH	HF	WF	MF	MF						
PWLN/R/L1616H06	●●	WNMG 06T3	16	16	100	22	16	20	LLSWN22	LLP13	LLCL13	LLCS106	HKY25R			
PWLN/R/L2020H06	●●	WNMG 06T3	20	20	125	22	20	25	LLSWN22	LLP13	LLCL13	LLCS106	HKY25R			
PWLN/R/L2525M06	●●	WNMG 06T3	25	25	150	22	25	32	LLSWN22	LLP13	LLCL13	LLCS106	HKY25R			

*1 Clamp Torque (N·m) : LLC106=2
*2 Please use shim no. LLSWN32 with 4.76mm thick inserts. When using inserts, shim should be ordered separately.

PVPN Facing, Copying **MP type**

Order Number	Stock	Insert Number	Dimensions (mm)								Shim	Lock Pin	Lock Screw	Step Ring	Wrench	
			H	B	LF	LH	HF	WF	MF	MF						
PVPNR/L2020K16	●●	VN A 1604	20	20	125	32	20	25	PV322	P115	HSP0500C	E03	HKY25R			
PVPNR/L2525M16	●●	VN G 1604	25	25	150	32	25	32	PV323	P115	HSP0500C	E03	HKY25R			

*1 Clamp Torque (N·m) : HSP0500C=2.5
*2 Please use shim no. PV021 and PV023 with RE0.4mm and RE1.2mm thick inserts. When using inserts, shim should be ordered separately.

DWLN External turning, Facing **DOUBLE CLAMP type**

Order Number	Stock	Insert Number	Dimensions (mm)								Shim	Lock Pin	Clamp	Clamp Screw	Wrench	
			H	B	LF	LH	HF	WF	MF	MF						
DWLN/R/L1616H06	●●	WNMG 06T3	16	16	100	25	16	20	LLSWN22	LLP23	DDK211	DCS1	DC0520T	TKY15F		
DWLN/R/L2020K06	●●	WNMG 06T3	20	20	125	25	20	25	LLSWN22	LLP23	DDK211	DCS1	DC0520T	TKY15F		
DWLN/R/L2525M06	●●	WNMG 06T3	25	25	150	25	25	32	LLSWN22	LLP23	DDK211	DCS1	DC0520T	TKY15F		
DWLN/R/L2020K08	●●	WNMG 0804	20	20	125	31	20	25	LLSWN42	LLP14	DDK2615	DCS1	DC06211	TKY20F		
DWLN/R/L2525M08	●●	WNMG 0804	25	25	150	31	25	32	LLSWN42	LLP14	DDK2615	DCS1	DC06211	TKY20F		
DWLN/R/L2525P08	●●	WNMG 0804	25	25	170	31	32	32	LLSWN42	LLP14	DDK2615	DCS1	DC06211	TKY20F		

*1 Clamp Torque (N·m) : DC0520T=3.5, DC06211=1.9
*2 Please use shim no. LLSWN32 with 4.76mm thick inserts. When using inserts, shim should be ordered separately.

LEGEND FOR STOCK STATUS MARK is shown on the left hand page of each double-page spread.

PRODUCT STANDARDS indicates order numbers, stock status (per right/left hand), applicable inserts, dimensions, and spare parts.

REFERENCE PAGE FOR APPLICABLE INSERTS indicates reference pages giving details of inserts that are applicable to the product.

PAGE REFERENCE indicates reference pages, including the above, on the right hand page of each double-page spread.

● : Inventory maintained in Japan.

DVPN type inserts > A128-A131
PVPN type inserts > A128-A131

CBN & PCD inserts > B042, B043, B070
RECOMMENDED CUTTING CONDITIONS > A076, B016

PWLN type inserts > A132-A135
DWLN type inserts > A132-A135
CBN inserts > B044

RECOMMENDED CUTTING CONDITIONS > A076, B016
SPARE PARTS > Q001
TECHNICAL DATA > R001

C020

C021

● To Order : Please specify
① order number and hand of tool (right/left).

TURNING TOOLS

EXTERNAL TURNING TOOLS

CLASSIFICATION.....	C002
IDENTIFICATION	C006
METHOD OF HOLDING	C007
STANDARD HOLDERS	
CN○○○INSERTS TOOL HOLDERS.....	C008
DN○○○INSERTS TOOL HOLDERS.....	C010
SN○○○INSERTS TOOL HOLDERS.....	C012
TN○○○INSERTS TOOL HOLDERS.....	C016
VN○○○INSERTS TOOL HOLDERS.....	C018
WN○○○INSERTS TOOL HOLDERS.....	C021
CC○○○INSERTS TOOL HOLDERS.....	C022
DC○○○INSERTS TOOL HOLDERS.....	C023
RC○○○INSERTS TOOL HOLDERS.....	C024
SC○○○INSERTS TOOL HOLDERS.....	C026
TC○○○INSERTS TOOL HOLDERS.....	C027
VC○○○INSERTS TOOL HOLDERS.....	C028
XC○○○INSERTS TOOL HOLDERS.....	C030
TL HOLDER	C035
●AL HOLDER (FOR ALUMINIUM TURNING)	
DE○○○INSERTS TOOL HOLDERS	C032
TE○○○INSERTS TOOL HOLDERS	C033
VD○○○INSERTS TOOL HOLDERS	C034







*Arranged by Alphabetical order

C008 DCLN	C016 PTGN
C010 DDJN	C018 PVJN
C016 DTGN	C020 PVPN
C018 DVJN	C019 PVVN
C020 DVPN	C021 PWLN
C019 DVVN	C022 SCLC
C021 DWLN	C023 SDJC
C009 MCLN	C032 SDJE
C012 MSBN	C023 SDNC
C014 MSSN	C032 SDNE
C017 MTJN	C025 SRDC
C009 PCBN	C025 SRGC
C008 PCLN	C026 SSSC
C011 PDHN	C033 STFE
C010 PDJN	C027 STGC
C024 PRDC	C033 STGE
C024 PRGC	C028 SVJC
C012 PSBN	C034 SVJD
C014 PSDN	C029 SVPC
C015 PSKN	C028 SVVC
C013 PSSN	C030 SXZC
C013 PSTN	C035 TLHR
C017 PTFN	

CLASSIFICATION(Negative insert)

EXTERNAL TURNING TOOLS







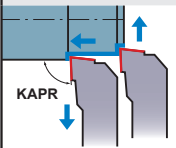
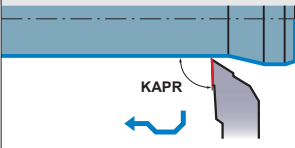
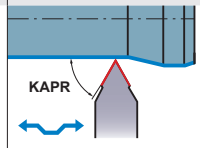

Tool Holder	Features Shank Size (H x W x L)	External Turning Facing		External Turning Copying		External Turning	
		KAPR=95°	KAPR=93°	KAPR=72.5°	KAPR=91°		
LL Holder 	<ul style="list-style-type: none"> ● Lever lock type. ● ISO standard. ● Various holder shapes. ● Suitable for light to heavy cutting. ● Economical negative insert. 10 x 10 x 70 25 x 25 x 150 12 x 12 x 80 32 x 25 x 170 16 x 16 x 100 32 x 32 x 170 20 x 20 x 125						
		PCLN ↻ C008	PWLN ↻ C021	PDJN ↻ C010		PTGN ↻ C016	
DOUBLE CLAMP Holder 	<ul style="list-style-type: none"> ● New double clamp type. ● Holds inserts securely. ● Excellent cutting edge tolerance. ● Economical negative insert. ● Small insert series. 16 x 16 x 100 25 x 25 x 150 20 x 20 x 125 32 x 25 x 170						
		DCLN ↻ C008	DWLN ↻ C021	DDJN ↻ C010	DVJN ↻ C018	DVVN ↻ C019	DTGN ↻ C016
DOUBLE CLAMP Holder (For heavy cutting) 	<ul style="list-style-type: none"> ● Double clamp holder type. ● Holds inserts securely. ● Suitable for heavy cutting. ● Negative insert. 32 x 32 x 170 40 x 40 x 200						
		MCLN ↻ C009					
WP Holder 	<ul style="list-style-type: none"> ● Double clamp holder type. ● Simple insert exchange. ● Economical negative insert. 20 x 20 x 125 25 x 25 x 150						
			MTJN ↻ C017				
MP Holder 	<ul style="list-style-type: none"> ● Pin lock type. ● 35° rhombic shape insert. ● Suitable for recessing. 20 x 20 x 125 25 x 25 x 150						
			PVJN ↻ C018	PVVN ↻ C019			

	External Turning	External Turning, Chamfering		External Turning, Facing, Chamfering	Facing		Facing, Copying	External Turning, Copying	Selection Standard					
		KAPR=75°	KAPR=60°	KAPR=45°	KAPR=45°	KAPR=75°	KAPR=91°	KAPR=107.5° 117.5°	Special Design (Positive inserts)	Economical	Low Cutting Resistance (Sharpness)	Clamp Rigidity	Operation Efficiency	Specialised
	PCBN ↻ C009	PSBN ↻ C012	SSTN ↻ C013	PSDN ↻ C014	PSSN ↻ C013	PSKN ↻ C015	PTFN ↻ C017	PDHN ↻ C011	PRGC ↻ C024	PRDC ↻ C024				
							DVPN ↻ C020							
	MSBN ↻ C012			MSSN ↻ C014										
							PVPN ↻ C020							

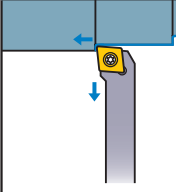
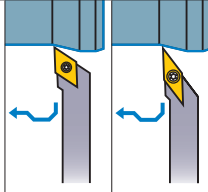
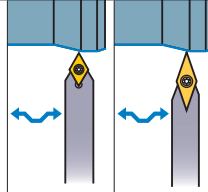
Note 1) ◎ : 1st recommendation. ○ : 2nd recommendation.

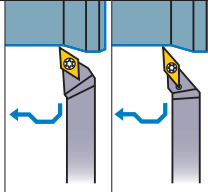
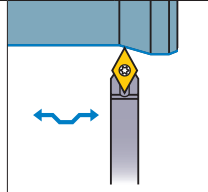
CLASSIFICATION(Positive insert)

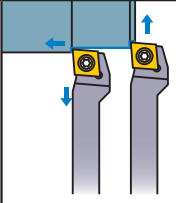
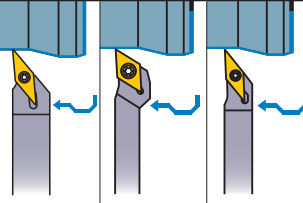
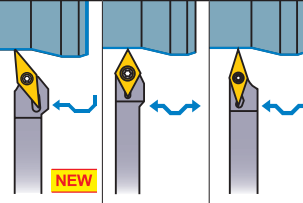
EXTERNAL TURNING TOOLS

Tool Holder	Features Shank Size (H x W x L)	External Turning, Facing	External Turning, Copying	
		KAPR=95°	KAPR=93° 95°	KAPR=62.5° 72.5°
	<ul style="list-style-type: none"> ● Double clamp holder type. ● 25° rhombic shape insert. ● Possible to machine a face relief with up to 60° inclination. 16 x 16 x 100 20 x 20 x 125 25 x 25 x 150			
SP Holder 	<ul style="list-style-type: none"> ● Screw-on type. ● Miniature holder with 7° positive insert. 8 x 8 x 60 10 x 10 x 70 12 x 12 x 80 16 x 16 x 100 20 x 20 x 125 25 x 25 x 150	 SCLC ↻ C022	 SDJC ↻ C023 SVJC ↻ C028	 SDNC ↻ C023 SVVC ↻ C028
AL Holder (For Aluminium turning) 	<ul style="list-style-type: none"> ● Screw-on type. ● 20° positive insert. (35° rhombic shape insert is 15°) ● High rake and good sharpness. 16 x 16 x 100 20 x 20 x 125 25 x 25 x 150		 SDJE ↻ C032 SVJD ↻ C034	 SDNE ↻ C032
TL Holder 	<ul style="list-style-type: none"> ● Taper lock type ● Excellent finished surface with round shape insert. 20 x 20 x 125 25 x 25 x 150 32 x 25 x 170			
SMALL TOOLS (Tools for front turning) 	<ul style="list-style-type: none"> ● Screw-on type. ● Tools to be equipped on gang type tool posts. ● Miniature holder with 7° positive insert. 8 x 8 x 125 10 x 10 x 125 12 x 12 x 150 16 x 16 x 150	 SCLC-SM ↻ D008	 SVLP-SM ↻ D010 SDJC-SM ↻ D009 SVJB-SM ↻ D010	 SVJC-SM ↻ D011 SDNC-SM ↻ D009 SVVB-SM ↻ D011
SMALL TOOLS (Tools for back turning) 	<ul style="list-style-type: none"> ● Screw-on type. ● Tools to be equipped on gang type tool posts. ● High rigidity due to designing of vertical insert. (BTA/CTB type) ● Back machining. (BTA/CTB type) 8 x 10 x 120 10 x 10 x 120 12 x 12 x 120 16 x 16 x 120			

	External Turning	External Turning, Facing, Chamfering	Facing	Facing, Copying	External Turning, Copying	Selection Standard				
	KAPR=90° 91°	KAPR=45°	KAPR=91°	KAPR=117.5°	Special Design	Economical	Low Cutting Resistance (Sharpness)	Clamp Rigidity	Operation Efficiency	Specialised
							◎	◎		
							◎			◎
										◎
										◎
					Special Design 					◎

Note 1) ◎ : 1st recommendation. ○ : 2nd recommendation.

IDENTIFICATION

■ LL Holder / Double Clamp Holder /
SP Holder / Profile Holder / AL Holder

P **C** **L** **N** **R** **25** **25** **M** **12**

EXTERNAL TURNING TOOLS

①Clamp Structure

D	Double Clamp Type
M	Wedge Lock Type Multiple Clamp Type
P	Lever Lock Type
S	Screw-on Type

③Cutting Angle
KAPR

A	90°Without Offset
B	75°
D	45°Neutral
E	60°
F	90°
G	90°With Offset
H	107.5°
J	93°
K	75°
L	95°
N	62.5°
P	117.5°
Q	105°
S	45°
T	60°
V	72.5°
Z	Special

④Insert Clearance

C	7°Positive
N	Negative
E	20°Positive

⑤Hand of Tool

R	Right Hand
L	Left Hand
N	Neutral

⑥Tool Size H/B (mm)
(Height and Width)

8	08
10	10
12	12
16	16
20	20
25	25
32	32

⑦Tool Length
LF (mm)

D	60
E	70
F	80
H	100
K	125
M	150
P	170
Q	180
R	200

⑧Cutting Edge Length (mm)

Inscribed Circle	Insert Shape					
	Square	Triangular	Round	Rhombic 80°	Rhombic 55°	Rhombic 35°
6.00	-	-	06	-	-	-
6.35	-	11	-	06	07	11
7.94	-	13	-	-	-	-
8.00	-	-	08	-	-	-
9.525	09	16	-	09	11	16
10.00	-	-	10	-	-	-
12.00	-	-	12	-	-	-
12.70	12	22	-	12	15	-
15.875	15	27	-	16	-	-
16.00	-	-	16	-	-	-
19.05	19	-	-	19	-	-
20.00	-	-	20	-	-	-
25.00	-	-	25	-	-	-
25.40	25	-	-	-	-	-
32.00	-	-	32	-	-	-

②Insert Shape

C	Rhombic 80°
D	Rhombic 55°
R	Round
S	Square
T	Triangular
V	Rhombic 35°
W	Trigon
X	Special Design

METHOD OF HOLDING

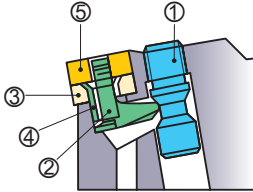
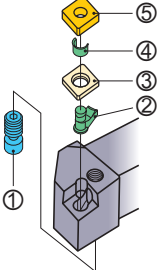
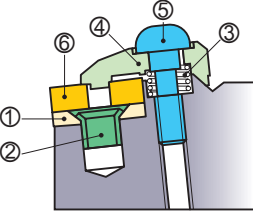
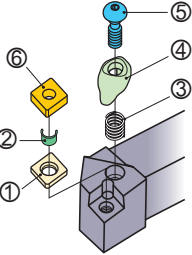
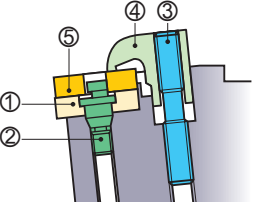
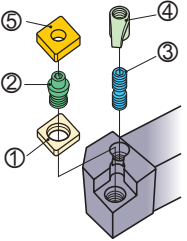
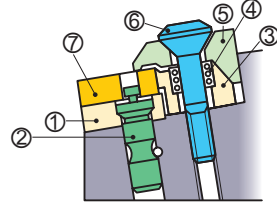
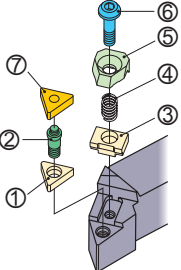
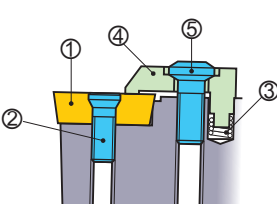
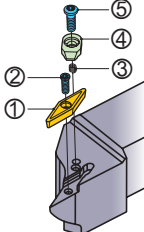
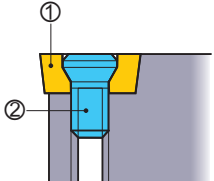
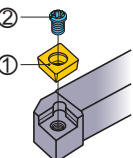
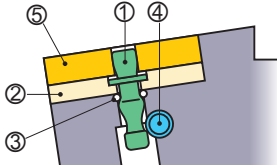
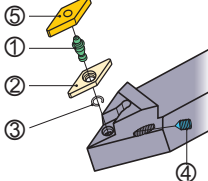
Type (Holder)	Structure		
Lever Lock (LL HOLDER)		<ul style="list-style-type: none"> ① Clamp Screw ② Lever ③ Shim ④ Shim Pin ⑤ Insert 	
Double Clamp (DOUBLE CLAMP) HOLDER		<ul style="list-style-type: none"> ① Shim ② Shim Pin ③ Spring ④ Clamp Bridge ⑤ Clamp Screw ⑥ Insert 	
Multiple Clamp (DOUBLE CLAMP) HOLDER (For heavy cutting)		<ul style="list-style-type: none"> ① Shim ② Shim Pin ③ Clamp Screw ④ Clamp Bridge ⑤ Insert 	
Wedge Lock (WP HOLDER)		<ul style="list-style-type: none"> ① Shim ② Shim Pin ③ Plate ④ Spring ⑤ Clamp Bridge ⑥ Clamp Screw ⑦ Insert 	
Two Action Double Clamp (PROFILE HOLDER)		<ul style="list-style-type: none"> ① Insert ② Clamp Screw (1) ③ Spring ④ Clamp Bridge ⑤ Clamp Screw (2) 	
Screw-on (SP HOLDER) (AL HOLDER)		<ul style="list-style-type: none"> ① Insert ② Clamp Screw 	
Pin Lock (MP HOLDER)		<ul style="list-style-type: none"> ① Lock Pin ② Shim ③ Stop Ring ④ Lock Screw ⑤ Insert 	

EXTERNAL TURNING TOOLS

CN INSERTS TOOL HOLDERS



TOOL NEWS

EXTERNAL TURNING TOOLS

Order Number		Stock		Insert Number	Dimensions (mm)							Accessories				
		R	L		H	B	LF	LH	HF	WF	Shim	Shim Pin	Clamp Lever	Clamp Screw*	Wrench	
PCLNR/L1616H09		●	●	CNMG	09T3	16	16	100	22	16	20	LLSCN3T3	LLP13	LLCL13	LLCS106	HKY25R
PCLNR/L2020K09		●	●		09T3	20	20	125	22	20	25	LLSCN3T3	LLP13	LLCL13	LLCS106	HKY25R
PCLNR/L2525M09		●	●		09T3	25	25	150	22	25	32	LLSCN3T3	LLP13	LLCL13	LLCS106	HKY25R
PCLNR/L2020K12		●	●	CNMA CNMG CNMM CNGA CNGG CNGM	1204	20	20	125	28	20	25	LLSCN42	LLP14	LLCL14	LLCS108	HKY30R
PCLNR/L2525M12		●	●		1204	25	25	150	28	25	32	LLSCN42	LLP14	LLCL14	LLCS108	HKY30R
PCLNR/L3225P12		●	●		1204	32	25	170	28	32	32	LLSCN42	LLP14	LLCL14	LLCS108	HKY30R
PCLNR/L3232P16		●	●		1606	32	32	170	32	32	40	LLSCN53	LLP15	LLCL25	LLCS508	HKY30R
PCLNR/L3232P19		●	●		1906	32	32	170	40	32	40	LLSCN63	LLP16	LLCL16	LLCS310	HKY40R

* Clamp Torque (N · m) : LLCS106=2.2, LLCS108=3.3, LLCS508=3.3, LLCS310=7.0

Order Number		Stock		Insert Number	Dimensions (mm)							Accessories					
		R	L		H	B	LF	LH	HF	WF	Shim*2	Shim Pin	Clamp Bridge	Spring	Clamp Screw*1	Wrench	
DCLNR/L1616H09		●	●	CNMG	09T3	16	16	100	25	16	20	LLSCN3T3 (LLSCN33)	LLP23	DCK2211	DCS2	DC0520T	TKY15F
DCLNR/L2020K09		●	●		09T3	20	20	125	25	20	25	LLSCN3T3 (LLSCN33)	LLP23	DCK2211	DCS2	DC0520T	TKY15F
DCLNR/L2525M09		●	●		09T3	25	25	150	25	25	32	LLSCN3T3 (LLSCN33)	LLP23	DCK2211	DCS2	DC0520T	TKY15F
DCLNR/L2020K12		●	●	CNMA CNMG CNMM CNGA CNGG CNGM	1204	20	20	125	29	20	25	LLSCN42	LLP14	DCK2613	DCS1	DC0621T	TKY20F
DCLNR/L2525M12		●	●		1204	25	25	150	29	25	32	LLSCN42	LLP14	DCK2613	DCS1	DC0621T	TKY20F
DCLNR/L3225P12		●	●		1204	32	25	170	29	32	32	LLSCN42	LLP14	DCK2613	DCS1	DC0621T	TKY20F
DCLNR/L3232P16		●	●		1606	32	32	170	32	32	40	LLSCN53	LLP15	DCK2613	DCS1	DC0621T	TKY20F

*1 Clamp Torque (N · m) : DC0520T=3.5, DC0621T=5.0

*2 Please use shim no. LLSCN33 with 3.18mm thick inserts. When using 3.18mm thick inserts, shim should be ordered separately.

Note 1) The insert photos are only examples. The letters refer to the chip breaker and the dimension refers to the inscribed circle.

● : Inventory maintained in Japan.

PCLN type inserts > A100-A106
DCLN type inserts > A100-A106

CBN & PCD inserts > B028-B031, B068
RECOMMENDED CUTTING CONDITIONS > A076, B015



TOOL NEWS

Order Number		Stock	Insert Number	Dimensions (mm)						Accessories					
				H	B	LF	LH	HF	WF	Shim	Shim Pin	Clamp Bridge	Clamp Screw*	Wrench	
MCLNR3232P19	●		CNMG CNMM CNMA	1906	32	32	170	36	32	40	MSCN63	MP6	CKW6	LS25	HKY40R
MCLNR4040R19	●			1906	40	40	200	36	40	50	MSCN63	MP6	CKW6	LS25	HKY40R

* Clamp Torque (N • m) : LS25=8.2

Order Number		Stock	Insert Number	Dimensions (mm)						Accessories					
				H	B	LF	LH	HF	WF	Shim	Shim Pin	Clamp Lever	Clamp Screw*	Wrench	
PCBNR/L2020K12	●●		CN●A CN●G CN●M	1204	20	20	125	28	20	17	LLSCN42	LLP14	LLCL14	LLCS108	HKY30R
PCBNR/L2525M12	●●			1204	25	25	150	25	25	22	LLSCN42	LLP14	LLCL14	LLCS108	HKY30R

* Clamp Torque (N • m) : LLCS108=3.3

MCLN type inserts > A100–A106
 PCBN type inserts > A100–A106
 CBN & PCD inserts > B028–B031, B068

RECOMMENDED CUTTING CONDITIONS > A076, B015
 SPARE PARTS > Q001
 TECHNICAL DATA > R001

EXTERNAL TURNING TOOLS







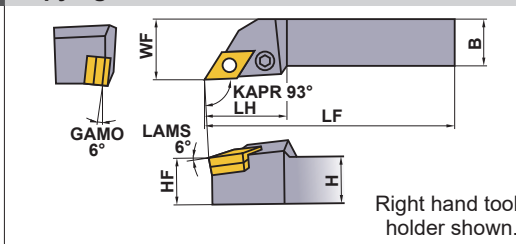
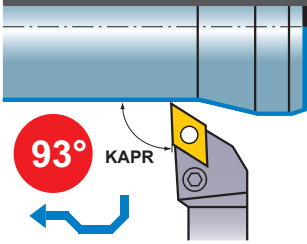

DN INSERTS TOOL HOLDERS



PDJN

External turning, Copying **LL type**



Finish	Light	Medium	Medium
FP	LP	MP	MK
 (15)	 (15)	 (15)	 (15)
Medium to Rough	Stainless	G Class	CBN
RP	MM	R/L	
 (15)	 (15)	 (15)	 (15)

Right hand tool holder shown.

Order Number	Stock		Insert Number	Dimensions (mm)							*2				
	R	L		H	B	LF	LH	HF	WF	Shim	Shim Pin	Clamp Lever	Clamp Screw	Wrench	
PDJNR/L2020K15	●	●	DNMA DNMG DNMM DNMX DNGA DNGG DNGM	1504	20	20	125	35	20	25	LLSDN43 (LLSDN42)	LLP14	LLCL24	LLCS108	HKY30R
PDJNR/L2525M15	●	●		1504	25	25	150	35	25	32	LLSDN43 (LLSDN42)	LLP14	LLCL24	LLCS108	HKY30R
PDJNR/L3225P15	●	●		1504	32	25	170	35	32	32	LLSDN43 (LLSDN42)	LLP14	LLCL24	LLCS108	HKY30R

*1 Clamp Torque (N · m) : LLCS108=3.3

*2 Please use shim no. LLSDN42 with 6.35mm thick inserts. When using 6.35mm thick inserts, shim should be ordered separately.





EXTERNAL TURNING TOOLS

C

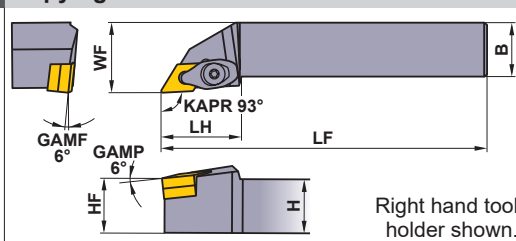
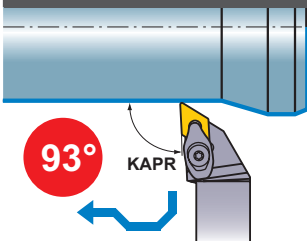
DDJN

External turning, **DOUBLE CLAMP type** Copying



Finish	Light	Medium	Medium
FP	LP	MP	MK
 (15)	 (11,15)	 (15)	 (11,15)
Medium to Rough	Stainless	G Class	CBN
RP	MM	R/L	
 (15)	 (15)	 (15)	 (15)

Right hand tool holder shown.

Order Number	Stock		Insert Number	Dimensions (mm)							*2					
	R	L		H	B	LF	LH	HF	WF	Shim	Shim Pin	Clamp Bridge	Spring	Clamp Screw	Wrench	
DDJNR/L1616H11	●	●	DNMG DNGA	1104	16	16	100	28	16	20	LLSDN32	LLP23	DCK2211	DCS2	DC0520T	TKY15F
DDJNR/L2020K11	●	●		1104	20	20	125	28	20	25	LLSDN32	LLP23	DCK2211	DCS2	DC0520T	TKY15F
DDJNR/L2525M11	●	●		1104	25	25	150	28	25	32	LLSDN32	LLP23	DCK2211	DCS2	DC0520T	TKY15F
DDJNR/L3225P11	●	●		1104	32	25	170	28	32	32	LLSDN32	LLP23	DCK2211	DCS2	DC0520T	TKY15F
DDJNR/L2020K15	●	●	DNMA DNMG DNMM DNMX DNGA DNGG DNGM	1504	20	20	125	37	20	25	LLSDN43 (LLSDN42)	LLP24	DCK2613	DCS1	DC0621T	TKY20F
DDJNR/L2525M15	●	●		1504	25	25	150	37	25	32	LLSDN43 (LLSDN42)	LLP24	DCK2613	DCS1	DC0621T	TKY20F
DDJNR/L3225P15	●	●		1504	32	25	170	37	32	32	LLSDN43 (LLSDN42)	LLP24	DCK2613	DCS1	DC0621T	TKY20F

*1 Clamp Torque (N · m) : DC0520T=3.5, DC0621T=5.0

*2 Please use shim no. LLSDN42 with 6.35mm thick inserts. When using 6.35mm thick inserts, shim should be ordered separately.

Note 1) The insert photos are only examples. The letters refer to the chip breaker and the dimension refers to the inscribed circle.

● : Inventory maintained in Japan.

PDJN type inserts > A107-A113
DDJN type inserts > A107-A113

CBN & PCD inserts > B032-B036, B068
RECOMMENDED CUTTING CONDITIONS > A076, B015

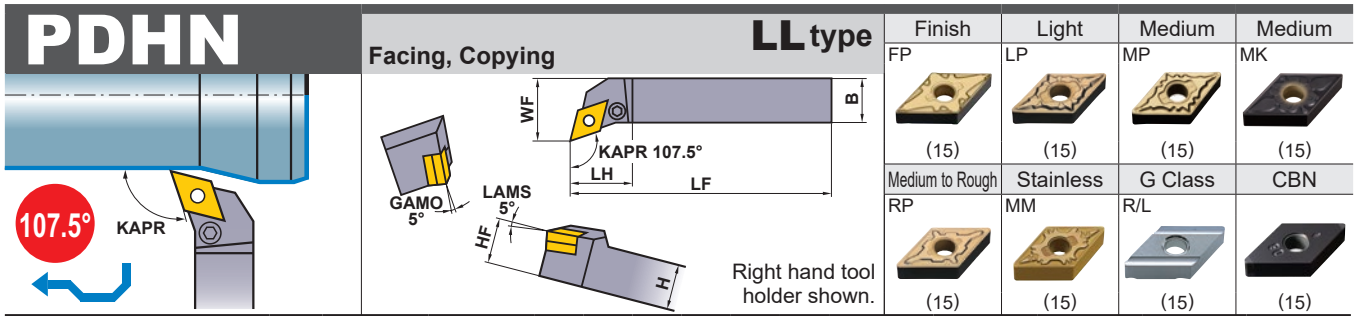

Order Number	Stock		Insert Number	Dimensions (mm)							*2					
	R	L		H	B	LF	LH	HF	WF	Shim	Shim Pin	Clamp Lever	Clamp Screw *1	Wrench		
PDHNR/L2020K15	●	●	DNMA DNMG DNMM	1504	20	20	125	34	20	25	LLSDN43 (LLSDN42)	LLP14	LLCL24	LLCS108	HKY30R	
PDHNR/L2525M15	●	●	DNGA DNMG DNMM	1504	25	25	150	34	25	32	LLSDN43 (LLSDN42)	LLP14	LLCL24	LLCS108	HKY30R	
PDHNR/L3225P15	●	●	DNGG DNMG DNMM	1504	32	25	170	34	32	32	LLSDN43 (LLSDN42)	LLP14	LLCL24	LLCS108	HKY30R	

*1 Clamp Torque (N • m) : LLCS108=3.3

*2 Please use shim no. LLSDN42 with 6.35mm thick inserts. When using 6.35mm thick inserts, shim should be ordered separately.

EXTERNAL TURNING TOOLS

SN INSERTS TOOL HOLDERS

PSBN

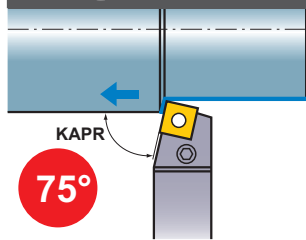

External turning LL type

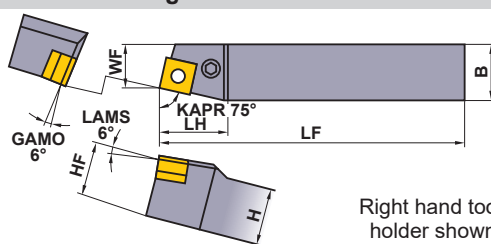

Finish	Light	Medium	Medium
FP (12)	LP (12)	MP (12)	MK (12,15,19)
Medium to Rough RP (12,15,19)	Stainless MM (12,15,19)	G Class R/L (09,12)	CBN (12)

Right hand tool holder shown.

EXTERNAL TURNING TOOLS

Order Number	Stock		Insert Number	Dimensions (mm)						Accessories						
	R	L		H	B	LF	LH	HF	WF	Shim	Shim Pin	Lever Spring	Clamp Lever	Clamp Screw*	Wrench	
PSBNR/L1212F09	●	●	SNMA SNMG SNGA SNMM SNGG	0903	12	12	80	20	12	13	—	—	HLS2	LLCL13S	LLCS105	HKY20R
PSBNR/L1616H09	●	●		0903	16	16	100	22	16	13	LLSSN33	LLP23	—	LLCL13	LLCS106	HKY25R
PSBNR/L2020K12	●	●		1204	20	20	125	28	20	17	LLSSN42	LLP14	—	LLCL14	LLCS108	HKY30R
PSBNR/L2525M12	●	●		1204	25	25	150	25	25	22	LLSSN42	LLP14	—	LLCL14	LLCS108	HKY30R
PSBNR/L2525M15	●	●		1506	25	25	150	33	25	22	LLSSN53	LLP15	—	LLCL25	LLCS508	HKY30R
PSBNR/L3232P19	●	●		1906	32	32	170	40	32	27	LLSSN63	LLP16	—	LLCL16	LLCS310	HKY40R

* Clamp Torque (N · m) : LLCS105=1.5, LLCS106=2.2, LLCS108=3.3, LLCS508=3.3, LLCS310=7.0

MSBN

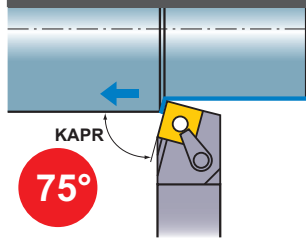

External turning DOUBLE CLAMP type For heavy cutting

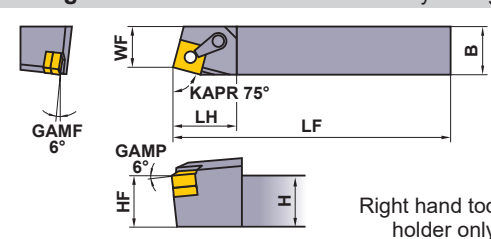

Medium	Medium	Medium	Medium to Rough
MH (19)	Standard (19)	MS (19)	RP (19)
Heavy HZ (19)	Heavy HX (19)	Heavy HL (19)	M Class Flat Top (19)

Right hand tool holder only.

Order Number	Stock		Insert Number	Dimensions (mm)						Accessories					
	R	L		H	B	LF	LH	HF	WF	Shim	Shim Pin	Clamp Bridge	Clamp Screw*	Wrench	
MSBNR3232P19	●	●	SNMG	1906	32	32	170	41	32	27	MSSN63	MP6	CKW6	LS25	HKY40R
MSBNR4040R19	●	●	SNMM SNMA	1906	40	40	200	41	40	35	MSSN63	MP6	CKW6	LS25	HKY40R

* Clamp Torque (N · m) : LS25=8.2

Note 1) The insert photos are only examples. The letters refer to the chip breaker and the dimension refers to the inscribed circle.

● : Inventory maintained in Japan.

PSBN type inserts > A115–A120
MSBN type inserts > A116–A120

CBN & PCD inserts > B037, B038, B069
RECOMMENDED CUTTING CONDITIONS > A076, B015

Order Number		Stock		Insert Number		Dimensions (mm)							Accessories				
		R	L			H	B	LF	LH	HF	WF	Shim	Shim Pin	Clamp Lever	Clamp Screw*	Wrench	
PSTNR/L1616H09		●	●	SNMA SNMG SNMM SNGA SNGG	0903	16	16	100	20	16	13	LLSSN33	LLP23	LLCL13	LLCS106	HKY25R	
PSTNR/L2020K12		●	●		1204	20	20	125	25	20	17	LLSSN42	LLP14	LLCL14	LLCS108	HKY30R	
PSTNR/L2525M12		●	●		1204	25	25	150	25	25	22	LLSSN42	LLP14	LLCL14	LLCS108	HKY30R	

* Clamp Torque (N · m) : LLCS106=2.2, LLCS108=3.3

Order Number		Stock		Insert Number		Dimensions (mm)								Accessories				
		R	L			H	B	LF	LH	HF	WF	WF2	Shim	Shim Pin	Clamp Lever	Clamp Screw*	Wrench	
PSSNR/L1616H09		●	●	SNMA SNMG SNMM SNGA SNGG	0903	16	16	100	22	16	20	14	LLSSN33	LLP23	LLCL13	LLCS106	HKY25R	
PSSNR/L2020K12		●	●		1204	20	20	125	31	20	25	17	LLSSN42	LLP14	LLCL14	LLCS108	HKY30R	
PSSNR/L2525M12		●	●		1204	25	25	150	31	25	32	24	LLSSN42	LLP14	LLCL14	LLCS108	HKY30R	
PSSNR/L3232P15		●	●		1506	32	32	170	34	32	40	29	LLSSN53	LLP15	LLCL25	LLCS508	HKY30R	
PSSNR/L3232P19		●	●		1906	32	32	170	40	32	40	27	LLSSN63	LLP16	LLCL16	LLCS310	HKY40R	

Note 1) When facing or chamfering only and using insert with right or left hand breaker, please use left hand insert for right hand holder and right hand insert for left hand holder.

* Clamp Torque (N · m) : LLCS106=2.2, LLCS108=3.3, LLCS508=3.3, LLCS310=7.0

PSTN type inserts	> A115 – A120
PSSN type inserts	> A115 – A120
CBN & PCD inserts	> B037, B038, B069

RECOMMENDED CUTTING CONDITIONS	> A076, B015
SPARE PARTS	> Q001
TECHNICAL DATA	> R001

EXTERNAL TURNING TOOLS

SN INSERTS TOOL HOLDERS

EXTERNAL TURNING TOOLS

MSSN

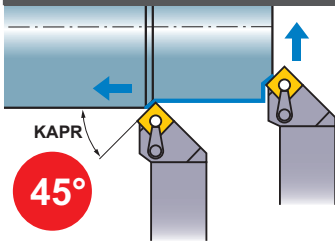





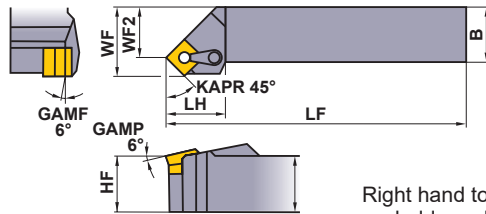







45°

External turning, Facing, Chamfering **DOUBLE CLAMP type**
For heavy cutting



Right hand tool holder only.

Medium MH	Medium Standard	Medium MS	Rough RP
 (19)	 (19)	 (19)	 (19)
Heavy HZ	Heavy HX	Heavy HL	M Class Flat Top
 (19)	 (19)	 (19)	 (19)

Order Number	Stock	Insert Number	Dimensions (mm)												
	R		H	B	LF	LH	HF	WF	WF2	Shim	Shim Pin	Clamp Bridge	Clamp Screw	Wrench	
MSSNR3232P19	●	SNMG SNMM SNMA	1906	32	32	170	44	32	40	27	MSSN63	MP6	CKW6	LS25*	HKY40R
MSSNR4040R19	●	SNMG SNMM SNMA	1906	40	40	200	44	40	50	37	MSSN63	MP6	CKW6	LS25	HKY40R

* Clamp Torque (N · m) : LS25=8.2

PSDN

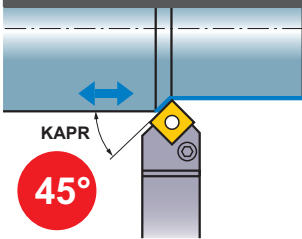





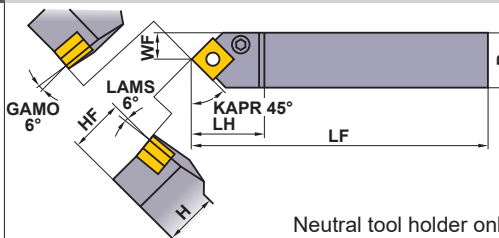

45°

External turning, Chamfering **LL type**



Neutral tool holder only.

Finish FP	Light LP	Medium MP	Medium MK
 (12)	 (12)	 (12)	 (12)
Medium to Rough RP	Stainless MM	G Class R/L	CBN
 (12)	 (12)	 (09,12)	 (12)

Order Number	Stock	Insert Number	Dimensions (mm)												
	N		H	B	LF	LH	HF	WF	Shim	Shim Pin	Lever Spring	Clamp Lever	Clamp Screw	Wrench	
PSDNN1212F09	●	SNMA SNMG SNMM SNGA SNGG	0903	12	12	80	20	12	6.0	—	—	HLS2	LLCL13S	LLCS105	HKY20R
PSDNN1616H09	●		0903	16	16	100	22	16	8.0	LLSSN33	LLP23	—	LLCL13	LLCS106	HKY25R
PSDNN2020K12	●		1204	20	20	125	28	20	10.0	LLSSN42	LLP14	—	LLCL14	LLCS108	HKY30R
PSDNN2525M12	●		1204	25	25	150	28	25	12.5	LLSSN42	LLP14	—	LLCL14	LLCS108	HKY30R
PSDNN3225P12	●		1204	32	25	170	28	32	12.5	LLSSN42	LLP14	—	LLCL14	LLCS108	HKY30R

* Clamp Torque (N · m) : LLCS105=1.5, LLCS106=2.2, LLCS108=3.3

Note 1) The insert photos are only examples. The letters refer to the chip breaker and the dimension refers to the inscribed circle.

● : Inventory maintained in Japan.

MSSN type inserts > A116–A120
PSDN type inserts > A115–A120

CBN & PCD inserts > B037, B038, B069
RECOMMENDED CUTTING CONDITIONS > A076, B015

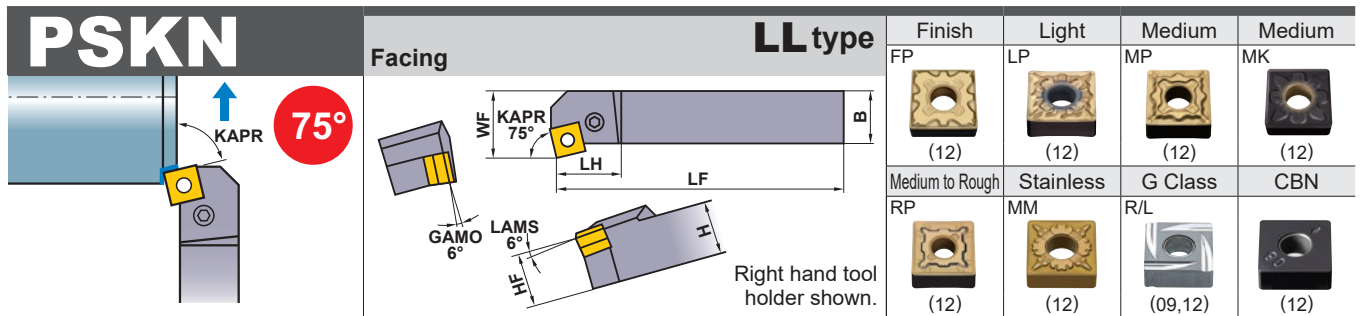

Order Number	Stock		Insert Number	Dimensions (mm)						Accessories					
	R	L		H	B	LF	LH	HF	WF	Shim	Shim Pin	Clamp Lever	Clamp Screw *	Wrench	
PSKNR/L1616H09	●	●	SNMA SNMG	0903	16	16	100	20	16	20	LLSSN33	LLP23	LLCL13	LLCS106	HKY25R
PSKNR/L2020K12	●	●	SNMM SNGA	1204	20	20	125	25	20	25	LLSSN42	LLP14	LLCL14	LLCS108	HKY30R
PSKNR/L2525M12	●	●	SNGA SNGG	1204	25	25	150	25	25	32	LLSSN42	LLP14	LLCL14	LLCS108	HKY30R

Note 1) When using insert with right or left hand breaker, please use left hand insert for right hand holder and right hand insert for left hand holder.

* Clamp Torque (N · m) : LLCS106=2.2, LLCS108=3.3

EXTERNAL TURNING TOOLS

PSKN type inserts > A115–A120
 CBN & PCD inserts > B037, B038, B069
 RECOMMENDED CUTTING CONDITIONS > A076, B015

SPARE PARTS > Q001
 TECHNICAL DATA > R001

EXTERNAL TURNING TOOLS

TN INSERTS TOOL HOLDERS



TOOL NEWS

EXTERNAL TURNING TOOLS

PTGN

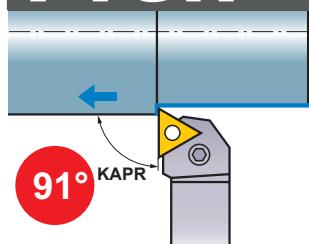

External turning LL type

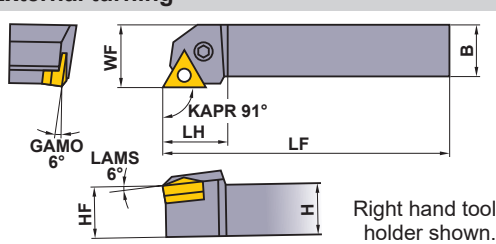

Finish	Light	Medium	Medium
FP (16)	LP (16,22)	MP (16,22)	MK (16,22)
Medium to Rough RP (16,22,27)	Stainless MM (16,22)	G Class R/L (11,16,22)	CBN (16)

Order Number	Stock		Insert Number	Dimensions (mm)							*2		Lever Spring	Clamp Lever	Clamp Screw *1	Wrench
	R	L		H	B	LF	LH	HF	WF	Shim	Shim Pin					
PTGNR/L1010E11	●	●	TNMA TNMG TNMM TNGA TNGG TNGM	1103	10	10	70	17	10	12	—	—	HLS1	LLCL12S	LLCS105	HKY20F
PTGNR/L1212F11	●	●		1103	12	12	80	17	12	16	—	—	HLS1	LLCL12S	LLCS105	HKY20F
PTGNR/L1616H16	●	●		1604	16	16	100	22	16	20	LLSTN32 (LLSTN33)	LLP13 (LLP23)	—	LLCL13	LLCS106	HKY25R
PTGNR/L2020K16	●	●		1604	20	20	125	22	20	25	LLSTN32 (LLSTN33)	LLP13 (LLP23)	—	LLCL13	LLCS106	HKY25R
PTGNR/L2525M16	●	●		1604	25	25	150	22	25	32	LLSTN32 (LLSTN33)	LLP13 (LLP23)	—	LLCL13	LLCS206	HKY25R
PTGNR/L2525M22	●	●		2204	25	25	150	28	25	32	LLSTN42	LLP14	—	LLCL14	LLCS108	HKY30R
PTGNR/L3225P22	●	●		2204	32	25	170	28	32	32	LLSTN42	LLP14	—	LLCL14	LLCS108	HKY30R
PTGNR/L3232P27	●	●		2706	32	32	170	35	32	40	LLSTN53	LLP15	—	LLCL25	LLCS508	HKY30R

*1 Clamp Torque (N · m) : LLCS105=1.5, LLCS106=2.2, LLCS206=2.2, LLCS108=3.3, LLCS508=3.3
PTGNR/L1010E11 · PTGNR/L1212F11 Clamp Torque (N · m) : LLCS105=1.0

*2 Please use shim no. LLSTN33 and shim pin no. LLP23 with 3.18mm thick inserts. When using 3.18mm thick inserts, shim and shim pin should be ordered separately.

DTGN

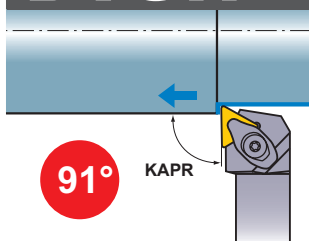

External turning DOUBLE CLAMP type

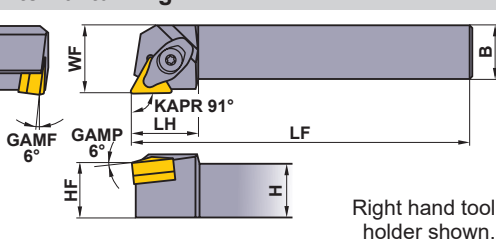

Finish	Light	Medium	Medium
FP (16)	LP (16)	MP (16)	MK (16)
Medium to Rough RP (16)	Stainless MM (16)	G Class R/L (16)	CBN (16)

Order Number	Stock		Insert Number	Dimensions (mm)							*2		Clamp Bridge	Spring	Clamp Screw *1	Wrench
	R	L		H	B	LF	LH	HF	WF	Shim	Shim Pin					
DTGNR/L1616H16	●	●	TNMA TNMG TNMM TNGA TNGG TNGM	1604	16	16	100	25	16	20	LLSTN32 (LLSTN33)	LLP23	DCK2211	DCS2	DC0520T	TKY15F
DTGNR/L2020K16	●	●		1604	20	20	125	25	20	25	LLSTN32 (LLSTN33)	LLP23	DCK2211	DCS2	DC0520T	TKY15F
DTGNR/L2525M16	●	●		1604	25	25	150	25	25	32	LLSTN32 (LLSTN33)	LLP23	DCK2211	DCS2	DC0520T	TKY15F

*1 Clamp Torque (N · m) : DC0520T=3.5

*2 Please use shim no. LLSTN33 with 3.18mm thick inserts. When using 3.18mm thick inserts, shim should be ordered separately.

Note 1) The insert photos are only examples. The letters refer to the chip breaker and the dimension refers to the inscribed circle.

● : Inventory maintained in Japan.

PTGN type inserts > A121-A127
DTGN type inserts > A121-A127

CBN & PCD inserts > B039-B041, B069
RECOMMENDED CUTTING CONDITIONS > A076, B015

Order Number		Stock		Insert Number	Dimensions (mm)					*2		*1				
		R	L		H	B	LF	LH	HF	WF	Shim	Shim Pin	Clamp Lever	Clamp Screw	Wrench	
PTFNR/L1616H16		●	●	TNMA TNMG TNMM TNGA TNGG TNGM	1604	16	16	100	22	16	20	LLSTN32 (LLSTN33)	LLP13 (LLP23)	LLCL13	LLCS106	HKY25R
PTFNR/L2020K16		●	●		1604	20	20	125	22	20	25	LLSTN32 (LLSTN33)	LLP13 (LLP23)	LLCL13	LLCS106	HKY25R
PTFNR/L2525M16		●	●		1604	25	25	150	22	25	32	LLSTN32 (LLSTN33)	LLP13 (LLP23)	LLCL13	LLCS206	HKY25R
PTFNR/L2525M22		●	●		2204	25	25	150	28	25	32	LLSTN42	LLP14	LLCL14	LLCS108	HKY30R

Note 1) When using insert with right or left hand breaker, please use left hand insert for right hand holder and right hand insert for left hand holder.

*1 Clamp Torque (N • m) : LLCS106=2.2, LLCS206=2.2, LLCS108=3.3

*2 Please use shim no. LLSTN33 and shim pin no. LLP23 with 3.18mm thick inserts. When using 3.18mm thick inserts, shim should be ordered separately.

Order Number		Stock		Insert Number	Dimensions (mm)					*2		*1						
		R	L		H	B	LF	LH	HF	WF	Shim	Shim Pin	Clamp Bridge	Side Lock Plate	Spring	Clamp Screw	Wrench	
MTJNR/L2020K16N		●	●	TNA TNG TNM TNMX	1604	20	20	125	31	20	25	WPSTN33	CCP33	CCK13	CPT13	MES2	SLCS105	HKY25R HKY40R
MTJNR/L2525M16N		●	●		1604	25	25	150	31	25	32	WPSTN33	CCP33	CCK13	CPT13	MES2	SLCS105	HKY25R HKY40R
MTJNR/L2525M22N		●	●		2204	25	25	150	38	25	32	WPSTN43	CCP34	CCK14	CPT14	MES3	SLCS106	HKY30R HKY40R

*1 Clamp Torque (N • m) : SLCS105=7.0, SLCS106=7.0

*2 HKY25R, HKY30R Wrench for Shim Pin, HKY40R Wrench for Clamp Screw.

PTFN type inserts	> A121 – A127
MTJN type inserts	> A121 – A127
CBN & PCD inserts	> B039 – B041, B069
RECOMMENDED CUTTING CONDITIONS	> A076, B015

SPARE PARTS	> Q001
TECHNICAL DATA	> R001

EXTERNAL TURNING TOOLS

VN[○] INSERTS TOOL HOLDERS







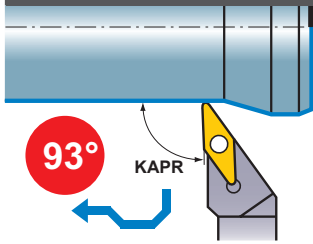

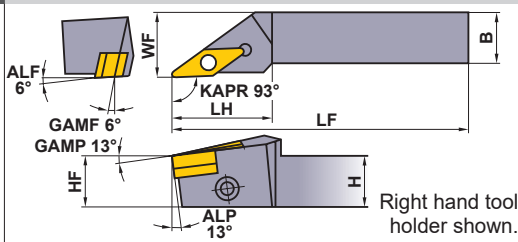

TOOL NEWS





PVJN

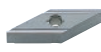

External turning, Copying **MP type**



Finish	Light	Medium	Medium
FP	LP	MP	MK
			
(16)	(16)	(16)	(16)
Medium	Stainless	G Class	CBN
Standard	MM	R/L	
			
(16)	(16)	(16)	(16)

Order Number	Stock		Insert Number	Dimensions (mm)							 *2  Lock Pin  *1  Stop Ring  Wrench				
	R	L		H	B	LF	LH	HF	WF	Shim	Lock Pin	Lock Screw	Stop Ring	Wrench	
PVJNR/L2020K16	●	●	VN [○] A VN [○] G VN [○] M	1604	20	20	125	32	20	25	PV322 (PV321) (PV323)	P11S	HSP05008C	E03	HKY25R
PVJNR/L2525M16	●	●	VN [○] A VN [○] G VN [○] M	1604	25	25	150	38	25	32		P11S	HSP05008C	E03	HKY25R

*1 Clamp Torque (N · m) : HSP05008C=2.5

*2 Please use shim no. PV321 and PV323 with RE0.4mm and RE1.2mm thick inserts. When using inserts, shim should be ordered separately.

EXTERNAL TURNING TOOLS

C



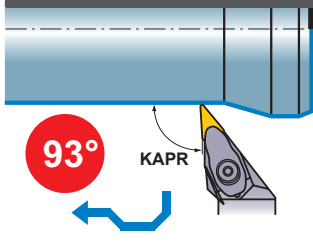

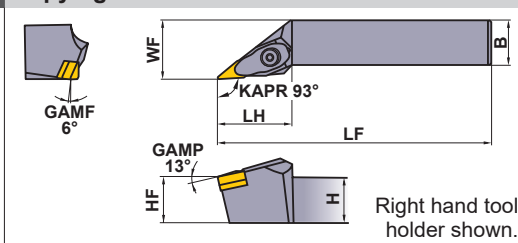

DVJN



External turning, **DOUBLE CLAMP type** Copying



Finish	Light	Medium	Medium
FP	LP	MP	MK
			
(16)	(16)	(16)	(16)
Medium	Stainless	G Class	CBN
Standard	MM	R/L	
			
(16)	(16)	(16)	(16)

Order Number	Stock		Insert Number	Dimensions (mm)							 Shim  Shim Pin  Clamp Bridge  Spring  * Clamp Screw  Wrench					
	R	L		H	B	LF	LH	HF	WF	Shim	Shim Pin	Clamp Bridge	Spring	Clamp Screw	Wrench	
DVJNR/L2020K16	●	●	VN [○] A VN [○] G VN [○] M	1604	20	20	125	41	20	25	DCSVN32	LLP13	DCK3113	DCS2	DC0520T	TKY15F
DVJNR/L2525M16	●	●	VN [○] A VN [○] G VN [○] M	1604	25	25	150	41	25	32	DCSVN32	LLP13	DCK3113	DCS2	DC0520T	TKY15F

* Clamp Torque (N · m) : DC0520T=3.5

Note 1) The insert photos are only examples. The letters refer to the chip breaker and the dimension refers to the inscribed circle.

● : Inventory maintained in Japan.

PVJN type inserts > A128—A131
DVJN type inserts > A128—A131

CBN & PCD inserts > B042, B043, B070
RECOMMENDED CUTTING CONDITIONS > A076, B015

Order Number		Stock N	Insert Number	Dimensions (mm)						Accessories						
				H	B	LF	LH	HF	WF	Shim	Shim Pin	Clamp Bridge	Spring	Clamp Screw *	Wrench	
DVVNN2020K16	●		VN-A VN-G VN-M	1604	20	20	125	44	20	10	DCSVN32	LLP13	DCK3113	DCS2	DC0520T	TKY15F
DVVNN2525M16	●		VN-A VN-G VN-M	1604	25	25	150	44	25	12.5	DCSVN32	LLP13	DCK3113	DCS2	DC0520T	TKY15F

* Clamp Torque (N · m) : DC0520T=3.5

Order Number		Stock N	Insert Number	Dimensions (mm)						Accessories					
				H	B	LF	LH	HF	WF	Shim *2	Lock Pin	Lock Screw *1	Stop Ring	Wrench	
PVVNN2020K16	●		VN-A VN-G VN-M	1604	20	20	125	38	20	10	PV322 (PV321) (PV323)	P11S	HSP05008C	E03	HKY25R
PVVNN2525M16	●		VN-A VN-G VN-M	1604	25	25	150	38	25	12.5	PV322 (PV321) (PV323)	P11S	HSP05008C	E03	HKY25R

*1 Clamp Torque (N · m) : HSP05008C=2.5

*2 Please use shim no. PV321 and PV323 with RE0.4mm and RE1.2mm thick inserts. When using inserts, shim should be ordered separately.

DVVN type inserts	> A128 – A131
PVVN type inserts	> A128 – A131
CBN & PCD inserts	> B042, B043, B070

RECOMMENDED CUTTING CONDITIONS	> A076, B015
SPARE PARTS	> Q001
TECHNICAL DATA	> R001

EXTERNAL TURNING TOOLS

VN[○] INSERTS TOOL HOLDERS







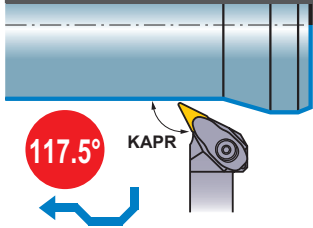

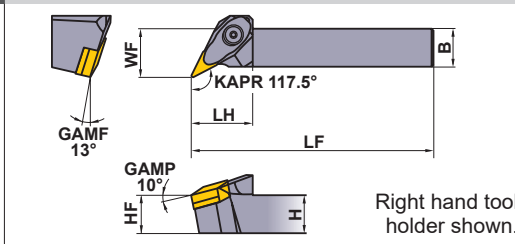

TOOL NEWS

DVPN



DOUBLE CLAMP type



Finish	Light	Medium	Medium
FP  (16)	LP  (16)	MP  (16)	MK  (16)
Medium Standard	Stainless MM	G Class R/L	CBN
 (16)	 (16)	 (16)	 (16)

Order Number	Stock		Insert Number	Dimensions (mm)						Accessories						
	R	L		H	B	LF	LH	HF	WF	Shim	Shim Pin	Clamp Bridge	Spring	Clamp Screw *	Wrench	
DVPNR/L2020K16	●	●	VN [○] A VN [○] G VN [○] M	1604	20	20	125	32	20	25	DCSVN32	LLP13	DCK3113	DCS2	DC0520T	TKY15F
DVPNR/L2525M16	●	●	VN [○] A VN [○] G VN [○] M	1604	25	25	150	32	25	32	DCSVN32	LLP13	DCK3113	DCS2	DC0520T	TKY15F

* Clamp Torque (N · m) : DC0520T=3.5

EXTERNAL TURNING TOOLS





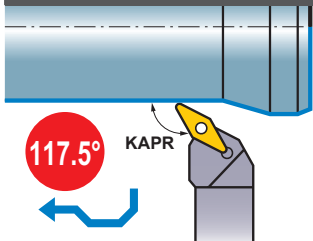

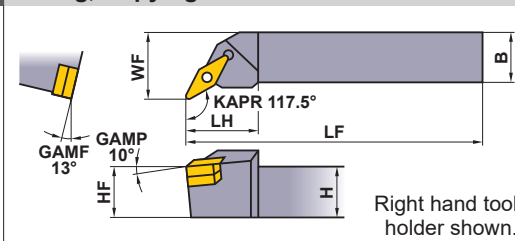

C

PVPN



MP type



Finish	Light	Medium	Medium
FP  (16)	LP  (16)	MP  (16)	MK  (16)
Medium Standard	Stainless MM	G Class R/L	CBN
 (16)	 (16)	 (16)	 (16)

Order Number	Stock		Insert Number	Dimensions (mm)						Accessories					
	R	L		H	B	LF	LH	HF	WF	Shim *2	Lock Pin	Lock Screw *1	Stop Ring	Wrench	
PVPNR/L2020K16	●	●	VN [○] A VN [○] G VN [○] M	1604	20	20	125	32	20	25	PV322 (PV321) (PV323)	P11S	HSP05008C	E03	HKY25R
PVPNR/L2525M16	●	●	VN [○] A VN [○] G VN [○] M	1604	25	25	150	32	25	32	PV322 (PV321) (PV323)	P11S	HSP05008C	E03	HKY25R

*1 Clamp Torque (N · m) : HSP05008C=2.5

*2 Please use shim no. PV321 and PV323 with RE0.4mm and RE1.2mm thick inserts. When using inserts, shim should be ordered separately.

Note 1) The insert photos are only examples. The letters refer to the chip breaker and the dimension refers to the inscribed circle.

● : Inventory maintained in Japan.

DVPN type inserts > A128—A131
PVPN type inserts > A128—A131

CBN & PCD inserts > B042, B043, B070
RECOMMENDED CUTTING CONDITIONS > A076, B015

WN INSERTS TOOL HOLDERS



TOOL NEWS

PWLN		External turning, Facing							LL type				Light	Medium		
													LP	MP		
													 (06)	 (06)		
													Stainless			
													MM		 (06)	
Order Number	Stock		Insert Number		Dimensions (mm)						*2		*1			
	R	L			H	B	LF	LH	HF	WF	Shim	Shim Pin	Clamp Lever	Clamp Screw	Wrench	
PWLN/L1616H06	●	●	WNMG	06T3	16	16	100	22	16	20	LLSWN3T3 (LLSWN32)	LLP13	LLCL13	LLCS106	HKY25R	
PWLN/L2020K06	●	●		06T3	20	20	125	22	20	25	LLSWN3T3 (LLSWN32)	LLP13	LLCL13	LLCS106	HKY25R	
PWLN/L2525M06	●	●		06T3	25	25	150	25	25	32	LLSWN3T3 (LLSWN32)	LLP13	LLCL13	LLCS106	HKY25R	

*1 Clamp Torque (N · m) : LLCS106=2.2

*2 Please use shim no. LLSWN32 with 4.76mm thick inserts. When using inserts, shim should be ordered separately.

DWLN		External turning, DOUBLE CLAMP type Facing							Finish											
									FP	LP	MP	MK								
													 (08)	 (06,08)	 (06,08)	 (08)				
													Medium Standard		Medium to Rough RP		Stainless MM		CBN	
													Standard		 (08)	 (08)	 (06,08)	 (08)		
Order Number	Stock		Insert Number		Dimensions (mm)						*2		*1							
	R	L			H	B	LF	LH	HF	WF	Shim	Shim Pin	Clamp Bridge	Spring	Clamp Screw	Wrench				
DWLN/L1616H06	●	●	WNMA WNMG WNGA	06T3	16	16	100	25	16	20	LLSWN3T3 (LLSWN32)	LLP23	DCK2211	DCS2	DC0520T	TKY15F				
DWLN/L2020K06	●	●		06T3	20	20	125	25	20	25	LLSWN3T3 (LLSWN32)	LLP23	DCK2211	DCS2	DC0520T	TKY15F				
DWLN/L2525M06	●	●		06T3	25	25	150	25	25	32	LLSWN3T3 (LLSWN32)	LLP23	DCK2211	DCS2	DC0520T	TKY15F				
DWLN/L2020K08	●	●		0804	20	20	125	31	20	25	LLSWN42	LLP14	DCK2613	DCS1	DC0621T	TKY20F				
DWLN/L2525M08	●	●		0804	25	25	150	31	25	32	LLSWN42	LLP14	DCK2613	DCS1	DC0621T	TKY20F				
DWLN/L3225P08	●	●		0804	32	25	170	31	32	32	LLSWN42	LLP14	DCK2613	DCS1	DC0621T	TKY20F				

*1 Clamp Torque (N · m) : DC0520T=3.5, DC0621T=5.0

*2 Please use shim no. LLSWN32 with 4.76mm thick inserts. When using inserts, shim should be ordered separately.

PWLN type inserts > A132–A135
 DWLN type inserts > A132–A136
 CBN inserts > B044

RECOMMENDED CUTTING CONDITIONS > A076, B015
 SPARE PARTS > Q001
 TECHNICAL DATA > R001

EXTERNAL TURNING TOOLS

EXTERNAL TURNING TOOLS

CC INSERTS TOOL HOLDERS

SCLC

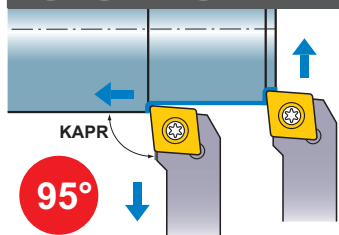

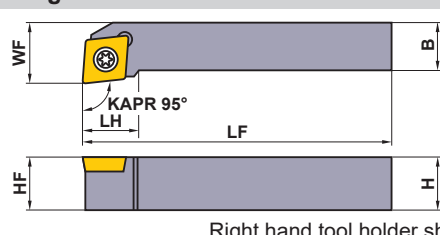

External turning,
Facing

SP type



Right hand tool holder shown.

Finish	Light	Medium	Stainless
FP  (06,09)	LP  (06,09)	MP  (06,09,12)	FM  (06,09)
Stainless	Stainless	Flat top	PCD/CBN
LM  (06,09)	MM  (06,09,12)	 (06,09,12)	 (06,09,12)

EXTERNAL TURNING TOOLS

C

Order Number	Stock		Insert Number	Dimensions (mm)							*1	
	R	L		H	B	LF	LH	HF	WF	Clamp Screw	Wrench	
SCLCR/L0808D06	●	●	CC○B CC○H #2 CC○T CC○W	0602	8	8	60	8.9	8	10	TS25	TKY08F
SCLCR/L1010E06	●	●		0602	10	10	70	8.9	10	12	TS25	TKY08F
SCLCR/L1212F09	●	●		09T3	12	12	80	13.6	12	16	TS43	TKY15F
SCLCR/L1616H12	●	●		1204	16	16	100	16.7	16	20	TS5	TKY25F

*1 Clamp Torque (N • m) : TS25=1.0, TS43=3.5, TS5=7.5

*2 When using CCGH and CCMH, it is recommended to use TS253 clamp screw.

Note 1) The insert photos are only examples. The letters refer to the chip breaker and the dimension refers to the inscribed circle.

● : Inventory maintained in Japan.

SCLC type inserts	> A140 – A147
CBN & PCD inserts	> B049 – B052, B072
RECOMMENDED CUTTING CONDITIONS	> A090, B015

DC INSERTS TOOL HOLDERS

SDJC		External turning, Copying		SP type		Finish		Light	Medium	Stainless
						FP	LP	MP	FM	
						(07,11)	(07,11)	(07,11)	(07,11)	
				Stainless		Stainless	Flat top	PCD/CBN		
						(07,11)	(07,11)	(07,11)	(07,11)	
				LM		MM	(07,11)	(07,11)		

Right hand tool holder shown.

Order Number	Stock		Insert Number	Dimensions (mm)						*			
	R	L		H	B	LF	LH	HF	WF	Clamp Screw	Wrench		
SDJCR/L1010E07	●	●	DCET DCGT	0702	10	10	70	12	10	12	TS25	TKY08F	
SDJCR/L1212F11	●	●	DCMW DCMT	11T3	12	12	80	18	12	16	TS43	TKY15F	
SDJCR/L1616H11	●	●	DCGW	11T3	16	16	100	18	16	20	TS43	TKY15F	

* Clamp Torque (N • m) : TS25=1.0, TS43=3.5

SDNC		External turning, Copying		SP type		Finish		Light	Medium	Stainless
						FP	LP	MP	FM	
						(07,11)	(07,11)	(07,11)	(07,11)	
				Stainless		Stainless	Flat top	PCD/CBN		
						(07,11)	(07,11)	(07,11)	(07,11)	
				LM		MM	(07,11)	(07,11)		

Neutral tool holder only.

Order Number	Stock		Insert Number	Dimensions (mm)						*			
	N			H	B	LF	HF	WF	Clamp Screw	Wrench			
SDNCN0808D07	●		DCET	0702	8	8	60	8	4	TS25	TKY08F		
SDNCN1010E07	●		DCGT	0702	10	10	70	10	5	TS25	TKY08F		
SDNCN1212F11	●		DCMW DCMT	11T3	12	12	80	12	6	TS43	TKY15F		
SDNCN1616H11	●		DCGW	11T3	16	16	100	16	8	TS43	TKY15F		

* Clamp Torque (N • m) : TS25=1.0, TS43=3.5

SDJC type inserts > A149–A154
 SDNC type inserts > A149–A154
 CBN & PCD inserts > B054–B056, B073

RECOMMENDED CUTTING CONDITIONS > A090, B015
 SPARE PARTS > Q001
 TECHNICAL DATA > R001

EXTERNAL TURNING TOOLS

RC INSERTS TOOL HOLDERS

PRGC

External turning,
Facing, Copying

LL type

Medium

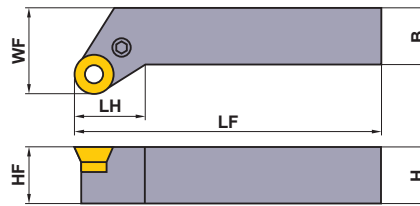
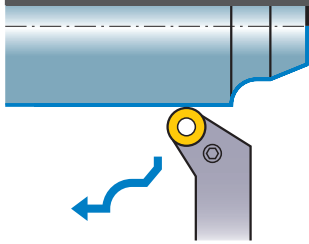

Right hand tool holder shown.

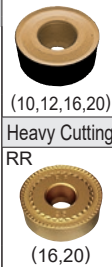

(10,12,16,20)

Heavy Cutting

RR

(16,20)

Order Number	Stock		Insert Number	Dimensions (mm)						Shim	Shim Pin	Clamp Lever	Clamp Screw	Wrench	
	R	L		H	B	LF	LH	HF	WF						
PRGCR/L2525M10	●	●	RCMX	1003M0	25	25	150	16.7	25	32	LLSRN103	LLP13	LLCL110	LLCS205	HKY20R
PRGCR/L2525M12	●	●		1204M0	25	25	150	17.5	25	32	LLSRN123	LLP13	LLCL112	LLCS106	HKY25R
PRGCR/L2525M16	●	●		1606M0	25	25	150	19.9	25	32	LLSRN164	LLP24	LLCL116	LLCS306	HKY25R
PRGCR/L3232P20	●	●		2006M0	32	32	170	23.8	32	40	LLSRN204	LLP15	LLCL120	LLCS508	HKY30R

* Clamp Torque (N · m) : LLCS205=1.5, LLCS106=2.2, LLCS306=2.2, LLCS508=3.3

EXTERNAL TURNING TOOLS

C

PRDC

External turning,
Copying

LL type

Medium

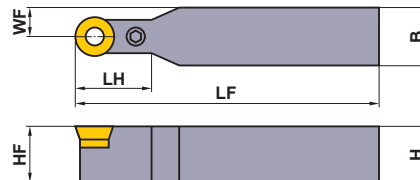
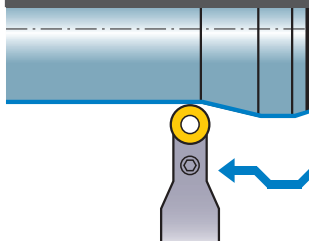

Neutral tool holder only.



(10,12,16,20)

Heavy Cutting

RR

(16,20)

Order Number	Stock	Insert Number	Dimensions (mm)						Shim	Shim Pin	Clamp Lever	Clamp Screw	Wrench	
	N		H	B	LF	LH	HF	WF						
PRDCN2020K10	●	RCMX	1003M0	20	20	125	23	20	10.0	LLSRN103	LLP13	LLCL110	LLCS205	HKY20R
PRDCN2525M12	●		1204M0	25	25	150	24	25	12.5	LLSRN123	LLP13	LLCL112	LLCS106	HKY25R
PRDCN3225P12	●		1204M0	32	25	170	24	32	12.5	LLSRN123	LLP13	LLCL112	LLCS106	HKY25R
PRDCN3225P16	●		1606M0	32	25	170	28	32	12.5	LLSRN164	LLP24	LLCL116	LLCS306	HKY25R
PRDCN3232P20	●		2006M0	32	32	170	33	32	16.0	LLSRN204	LLP15	LLCL120	LLCS508	HKY30R

* Clamp Torque (N · m) : LLCS205=1.5, LLCS106=2.2, LLCS306=2.2, LLCS508=3.3

Note 1) The insert photos are only examples. The letters refer to the chip breaker and the dimension refers to the inscribed circle.

● : Inventory maintained in Japan.

PRGC type inserts > A156
PRDC type inserts > A156
RECOMMENDED CUTTING CONDITIONS > A090

SRGC		External turning, Facing, Copying							SP type			
									Medium – Finish Cutting AZ (08)			
									Medium Standard (06,08)			
Order Number	Stock		Insert Number		Dimensions (mm)				*			
	R	L			H	B	LF	LH	HF	WF	Clamp Screw	Wrench
SRGCR/L1616H06	●	●	RCMT	0602	16	16	100	10	16	20	TS25	TKY08F
SRGCR/L1616H08	●	●	RCGT	0803	16	16	100	14.5	16	22	TS3	TKY08F

* Clamp Torque (N · m) : TS25=1.0, TS3=1.0

C

EXTERNAL TURNING TOOLS

SRDC		External turning, Copying							SP type			
									Medium – Finish Cutting AZ (08)			
									Medium Standard (06,08)			
Order Number	Stock		Insert Number		Dimensions (mm)				*			
	N				H	B	LF	LH	HF	WF	Clamp Screw	Wrench
SRDCN1616H06	●	●	RCMT	0602	16	16	100	12	16	8	TS25	TKY08F
SRDCN1616H08	●	●	RCGT	0803	16	16	100	16	16	8	TS3	TKY08F

* Clamp Torque (N · m) : TS25=1.0, TS3=1.0

SRGC type inserts > A156
 SRDC type inserts > A156
 RECOMMENDED CUTTING CONDITIONS > A090

SPARE PARTS > Q001
 TECHNICAL DATA > R001

C025

EXTERNAL TURNING TOOLS

SC INSERTS TOOL HOLDERS

SSSC

External turning,
Facing, Chamfering

SP type

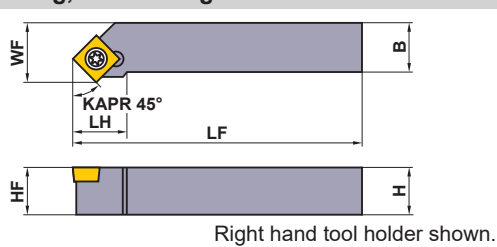
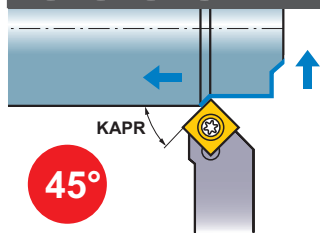

Finish	Light	Medium	Stainless
FP (09)	LP (09)	MP (09)	FM (09)
Stainless	Stainless	Medium	Flat top
LM (09)	MM (09)	Standard (09)	(09)

EXTERNAL TURNING TOOLS

C

Order Number	Stock		Insert Number	Dimensions (mm)						*		
	R	L		H	B	LF	LH	HF	WF	Clamp Screw	Wrench	
SSSCR/L1212F09	●	●	SCMW SCMT	09T3	12	12	80	15.2	12	13	TS43	TKY15F
SSSCR/L1616H09	●	●		09T3	16	16	100	15.2	16	17	TS43	TKY15F

* Clamp Torque (N · m) : TS43=3.5

Note 1) The insert photos are only examples. The letters refer to the chip breaker and the dimension refers to the inscribed circle.







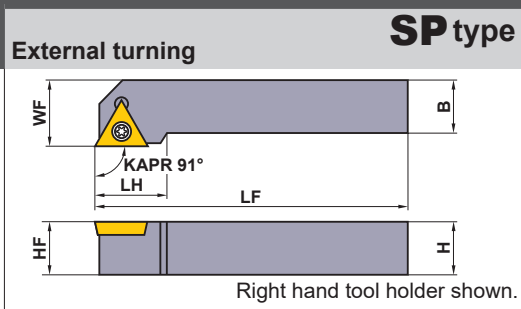
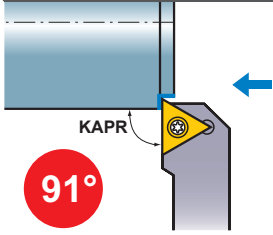

● : Inventory maintained in Japan.



SSSC type inserts > A157, A158
RECOMMENDED CUTTING CONDITIONS > A090

TC INSERTS TOOL HOLDERS

STGC



Finish	Light	Medium	Stainless
FP  (11,16)	LP  (11,16)	MP  (11,13,16)	FM  (11,16)
Stainless	Stainless	Flat top	PCD/CBN
LM  (11,16)	MM  (11,13,16)	 (11,13,16)	 (11,13,16)

Order Number	Stock		Insert Number	Dimensions (mm)							* 			
	R	L		H	B	LF	LH	HF	WF	Clamp Screw		Wrench		
STGCR/L1010E11	●	●	TCGT 1102	10	10	70	13.5	10	12	TS25		TKY08F		
STGCR/L1212F13	●	●	TCMT TCGW	12	12	80	17.6	12	16	TS3		TKY08F		
STGCR/L1616H16	●	●	TCMW 16T3	16	16	100	20.7	16	20	TS43		TKY15F		

* Clamp Torque (N • m) : TS25=1.0, TS3=1.0, TS43=3.5

EXTERNAL TURNING TOOLS

STGC type inserts > A160–A162
CBN & PCD inserts > B057, B074

RECOMMENDED CUTTING CONDITIONS > A090, B015
SPARE PARTS > Q001
TECHNICAL DATA > R001

EXTERNAL TURNING TOOLS

VC INSERTS TOOL HOLDERS



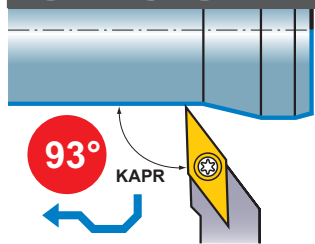



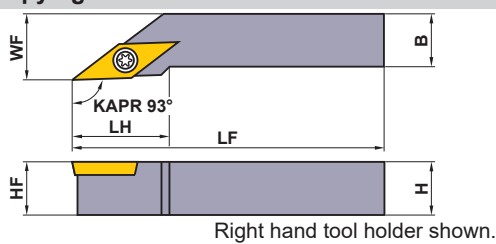

SVJC



External turning, Copying **SP type**







Right hand tool holder shown.

Finish	Light	Medium	Stainless
FP	LP	MP	FM
 (11,16)	 (11,16)	 (16)	 (11,16)
Stainless	Stainless	Medium	Flat top
LM	MM	Standard	
 (11,16)	 (16)	 (11,16)	 (11,16)

EXTERNAL TURNING TOOLS

C

Order Number	Stock		Insert Number	Dimensions (mm)										
	R	L		H	B	LF	LH	HF	WF					Shim
SVJCR/L1010E11	●	●	VCGT VCGW VCMT VCMW	1103	10	10	70	17	10	12	—	—	TS25	①TKY08F
SVJCR/L1616H16	●	●		1604	16	16	100	25	16	20	—	—	TS43	①TKY15F
SVJCR/L2020K16	●	●		1604	20	20	125	40	20	25	SPSVN32	BCP141	TS44	②TKY15R
SVJCR/L2525M16	●	●		1604	25	25	150	40	25	32	SPSVN32	BCP141	TS44	②TKY15R

* Clamp Torque (N · m) : TS25=1.0, TS43=3.5, TS44=3.5



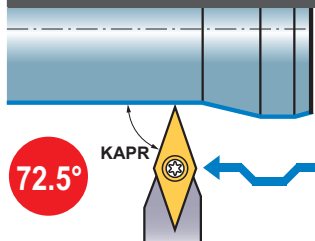



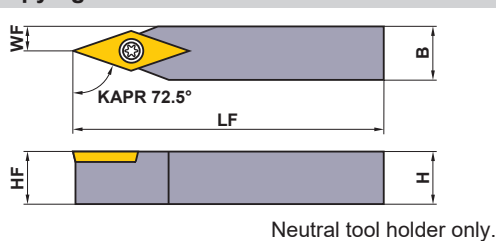

SVVC







External turning, Copying **SP type**



Neutral tool holder only.

Finish	Light	Medium	Stainless
FP	LP	MP	FM
 (16)	 (16)	 (16)	 (16)
Stainless	Stainless	Medium	Flat top
LM	MM	Standard	
 (16)	 (16)	 (16)	 (16)

Order Number	Stock		Insert Number	Dimensions (mm)									
	N			H	B	LF	HF	WF	Shim				
SVVCN1616H16	●		VCGT VCGW VCMT VCMW	1604	16	16	100	16	8	—	—	TS43	①TKY15F
SVVCN2020K16	●			1604	20	20	125	20	10	SPSVN32	BCP141	TS44	②TKY15R
SVVCN2525M16	●			1604	25	25	150	25	12.5	SPSVN32	BCP141	TS44	②TKY15R

* Clamp Torque (N · m) : TS43=3.5, TS44=3.5

Note 1) The insert photos are only examples. The letters refer to the chip breaker and the dimension refers to the inscribed circle.

● : Inventory maintained in Japan.

SVJC type inserts > A170–A172
SVVC type inserts > A170–A172





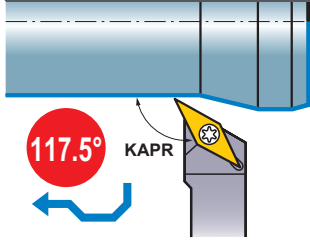

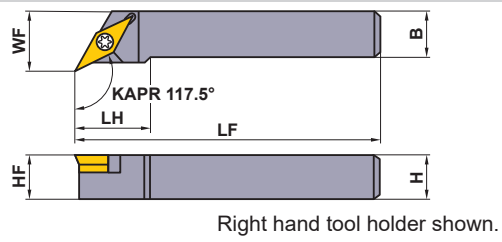

CBN & PCD inserts > B062, B077
RECOMMENDED CUTTING CONDITIONS > A090, B015





SVPC

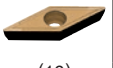

Facing, Copying **SP type**



Finish	Light	Medium	Stainless
FP	LP	MP	FM
 (16)	 (16)	 (16)	 (16)
Stainless	Stainless	Medium	Flat top
LM	MM	Standard	
 (16)	 (16)	 (16)	 (16)

Order Number	Stock		Insert Number	Dimensions (mm)										
	R	L		H	B	LF	LH	HF	WF	Shim	Shim Pin	Clamp Screw *	Wrench	
SVPCR/L2020K16	●	●	VCGT VCGW VCMT VCMW	1604	20	20	125	30	20	25	SPSVN32	BCP141	TS44	TKY15R
SVPCR/L2525M16	●	●	VCGT VCGW VCMT VCMW	1604	25	25	150	30	25	32	SPSVN32	BCP141	TS44	TKY15R

* Clamp Torque (N · m) : TS44=3.5

EXTERNAL TURNING TOOLS

SVPC type inserts	> A170 – A172	SPPARE PARTS	> Q001
CBN inserts	> B062, B077	TECHNICAL DATA	> R001
RECOMMENDED CUTTING CONDITIONS	> A090, B015		

EXTERNAL TURNING TOOLS

XC INSERTS TOOL HOLDERS



TOOL NEWS

SXZC

External turning, Copying

Profile Holder

Finish SVX

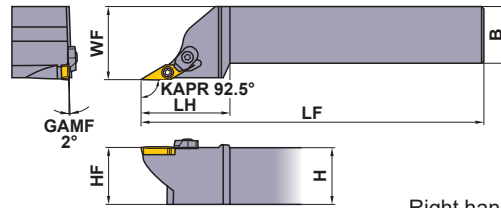
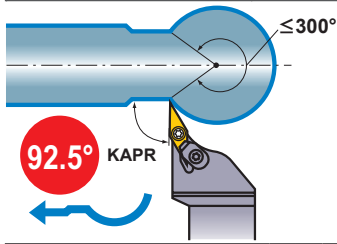

Right hand tool holder shown.



(15)

EXTERNAL TURNING TOOLS

C

Order Number	Stock		Insert Number	Dimensions (mm)						* Clamp Screw		* Clamp Bridge Screw		Spring	Insert Wrench	Wrench for clamp bridge
	R	L		H	B	LF	LH	HF	WF	Clamp Screw	Clamp Bridge	Clamp Bridge Screw				
SXZCR/L1616H15	●	●	XCMT	1503	16	16	100	35	16	20	TS255	AMS3	AJS3010T10	ASS2	TKY08F	TKY10F
SXZCR/L2020K15	●	●		1503	20	20	125	35	20	25	TS255	AMS3	AJS3010T10	ASS2	TKY08F	TKY10F
SXZCR/L2525M15	●	●		1503	25	25	150	40	25	32	TS255	AMS3	AJS3010T10	ASS2	TKY08F	TKY10F

* Clamp Torque (N · m) : TS255=1.0, AJS3010T10=2.5

Applicable range

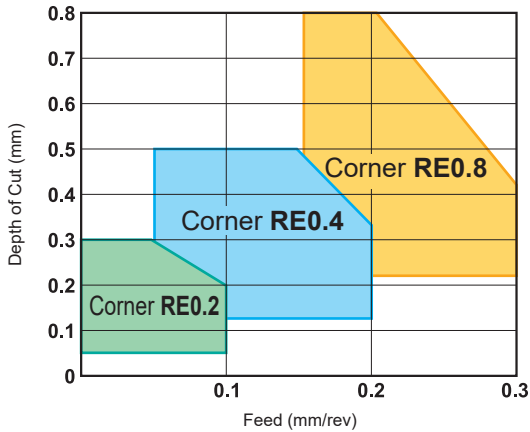

RECOMMENDED CUTTING CONDITIONS

Work Material	Hardness	Grade	Cutting Speed (m/min)
P Mild Steel	≤180HB	UE6020	250 (150–350)
	Carbon Steel, Alloy Steel	150HB–250HB	UE6020
M Stainless Steel	≤200HB	VP15TF	100 (70–120)

The above cutting conditions are general guidelines.

Adjustments maybe necessary depending on machine rigidity, workpiece geometry and clamping.

Note 1) The insert photos are only examples. The letters refer to the chip breaker and the dimension refers to the inscribed circle.

● : Inventory maintained in Japan.

NOTE

Notes when end face copying

Pay special attention to the following when face copying.

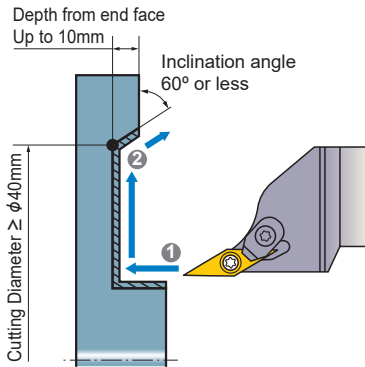

Machining of an outer diameter (Step ①)

- To prevent burr formation, the depth of cut should be below half the nose radius.

Machining of an inclination (Step ②)

- To reduce the contact length of chips, the depth of cut should be below half the nose radius.
- To prevent interference between the tool and the workpiece, the cutting diameter should be 40mm or larger, inclination angle 60° or less and depth from the end face up to 10mm.

When changing inserts

- When indexing the inserts, it is recommended to preset the cutting edge position to maintain machining accuracy.

Not possible

● Machining of V-pulleys

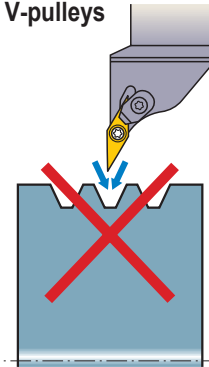

When machining V-pulleys, use a VNMG insert.



EXTERNAL TURNING TOOLS [FOR ALUMINIUM TURNING]

DE INSERTS TOOL HOLDERS

SDJE

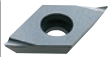

External turning,
Copying

AL type

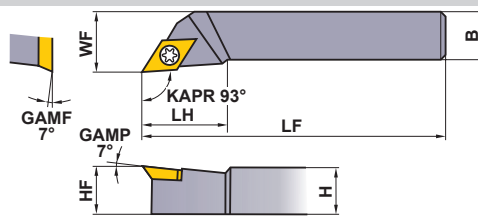
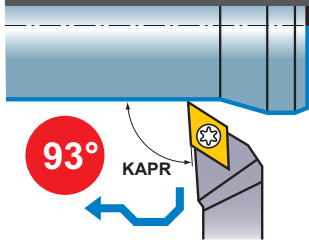
Finish	Medium
R/L-F  (15)	R/L  (15)
PCD	
R/L-F  (15)	



Right hand tool holder shown.

Order Number	Stock		Insert Number	Dimensions (mm)						* 		
	R	L		H	B	LF	LH	HF	WF			Clamp Screw
SDJER/L1616H15	●	●	DEGX	1504	16	16	100	27	16	20	CS451190T	TKY20F
SDJER/L2020K15	●	●		1504	20	20	125	35	20	25	CS451190T	TKY20F
SDJER/L2525M15	●	●		1504	25	25	150	35	25	32	CS451190T	TKY20F

* Clamp Torque (N · m) : CS451190T=5.0



EXTERNAL TURNING TOOLS

C

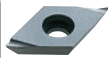

SDNE

External turning,
Copying

AL type

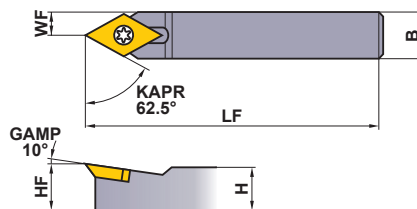
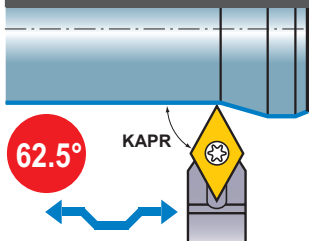
Finish	Medium
R/L-F  (15)	R/L  (15)
PCD	
R/L-F  (15)	



Order Number	Stock		Insert Number	Dimensions (mm)						* 	
	R	L		H	B	LF	HF	WF	Clamp Screw		
SDNEN1616H15	●		DEGX	1504	16	16	100	16	8	CS451190T	TKY20F
SDNEN2020K15	●			1504	20	20	125	20	10	CS451190T	TKY20F
SDNEN2525M15	●			1504	25	25	150	25	12.5	CS451190T	TKY20F

* Clamp Torque (N · m) : CS451190T=5.0

RECOMMENDED CUTTING CONDITIONS

Work Material	Grade	Cutting Speed (m/min)	Feed (mm/rev)	Depth of Cut (mm)
N Aluminium Alloy	HTi10	400	0.05-0.3	0.2-3.0
	MD220	800	0.05-0.3	0.2-0.5

Note 1) The insert photos are only examples. The letters refer to the chip breaker and the dimension refers to the inscribed circle.

● : Inventory maintained in Japan.

SDJE type inserts > A155
SDNE type inserts > A155
PCD inserts > B079

TE INSERTS TOOL HOLDERS

STGE		External turning							AL type		Medium	PCD
									R/L	R/L	(16)	(16)
Order Number	Stock		Insert Number	Dimensions (mm)					*			
	R	L		H	B	LF	LH	HF	WF	Clamp Screw	Wrench	
STGER/L1616H16	●	●	TEGX	1603	16	16	100	22	16	20	FC400890T	TKY10F
STGER/L2020K16	●	●		1603	20	20	125	22	20	25	FC400890T	TKY10F
STGER/L2525M16	●	●		1603	25	25	150	22	25	32	FC400890T	TKY10F

* Clamp Torque (N · m) : FC400890T=2.5

STFE		Facing							AL type		Medium	PCD
									R/L	R/L	(16)	(16)
Order Number	Stock		Insert Number	Dimensions (mm)					*			
	R	L		H	B	LF	LH	HF	WF	Clamp Screw	Wrench	
STFER/L1616H16	●	●	TEGX	1603	16	16	100	22	16	20	FC400890T	TKY10F
STFER/L2020K16	●	●		1603	20	20	125	22	20	25	FC400890T	TKY10F
STFER/L2525M16	●	●		1603	25	25	150	22	25	32	FC400890T	TKY10F

Note 1) When using insert with right or left hand breaker, please use left hand insert for right hand holder and right hand insert for left hand holder.

* Clamp Torque (N · m) : FC400890T=2.5

RECOMMENDED CUTTING CONDITIONS

Work Material	Grade	Cutting Speed (m/min)	Feed (mm/rev)	Depth of Cut (mm)
N Aluminium Alloy	HTi10	400	0.05-0.3	0.2-3.0
	MD220	800	0.05-0.3	0.2-0.5

STGE type inserts > A163

STFE type inserts > A163

PCD inserts > B079

SPARE PARTS > Q001

TECHNICAL DATA > R001

EXTERNAL TURNING TOOLS [FOR ALUMINIUM]

VD INSERTS TOOL HOLDERS

SVJD

External turning,
Copying

AL type

Finish

R/L

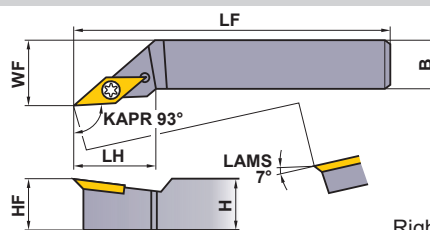
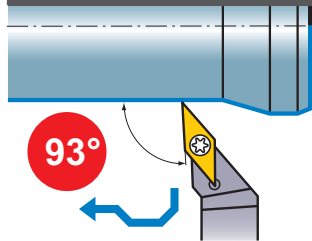

Right hand tool holder shown.



(16)

PCD

R/L-F



(16)

EXTERNAL TURNING TOOLS

C

Order Number	Stock		Insert Number	Dimensions (mm)						* Clamp Screw	Wrench	
	R	L		H	B	LF	LH	HF	WF			
SVJDR/L1616H16	●	●	VDGX	1603	16	16	100	30	16	20	FC400890T	TKY10F
SVJDR/L2020K16	●	●		1603	20	20	125	30	20	25	FC400890T	TKY10F
SVJDR/L2525M16	●	●		1603	25	25	150	30	25	32	FC400890T	TKY10F

* Clamp Torque (N · m) : FC400890T=2.5

RECOMMENDED CUTTING CONDITIONS

Work Material	Grade	Cutting Speed (m/min)	Feed (mm/rev)	Depth of Cut (mm)
N Aluminium Alloy	HTi10	400	0.05—0.3	0.2—3.0
	MD220	800	0.05—0.3	0.2—0.5

Note 1) The insert photos are only examples. The letters refer to the chip breaker and the dimension refers to the inscribed circle.

● : Inventory maintained in Japan.
▲ : Inventory maintained in Japan. To be replaced by new products.

SVJD type inserts > A173
PCD inserts > B080

TL HOLDER

HOLDER

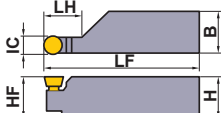
Geometry	Revised order number	Conventional order number	Stock	Insert Number	Dimensions (mm)					
					IC	H	B	HF	LF	LH
TLHR (External turning, Copying) 	TLHR2020K5	TLHR2020K5	●	RTG05A	5	20	20	20	125	16
	TLHR2020K6	TLHR2020K6	●	RTG06A	6	20	20	20	125	16
	TLHR2525M7	TLHR2525M7	●	RTG07A	7	25	25	25	150	20
	TLHR3225P10	TLHR54P10	●	RTG10A	10	32	25	32	170	25

INSERTS

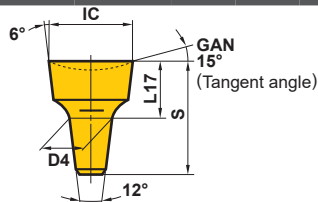

Order Number	Stock		Dimensions (mm)			
	Carbide		IC	S	D4	L17
	UTi20T	HTi10				
RTG05A	●	●	5	7.5	2.5	3.5
RTG06A	●	●	6	7.5	3.5	3.5
RTG07A	●		7	11	3.5	5
RTG08A	●	●	8	11	4.5	5
RTG10A	●	●	10	14	5.5	6.5

INSERTS (CBN)

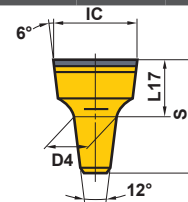

Order Number	Stock	Dimensions (mm)			
	CBN	IC	S	D4	L17
	MB825				
RTG05A	▲	5	7.5	2.5	3.5
RTG06A	▲	6	7.5	3.5	3.5
RTG07A	▲	7	11	3.5	5
RTG08A	▲	8	11	4.5	5
RTG10A	▲	10	14	5.5	6.5

INSERT SEAT LOCATION

When manufacturing a special tool holder, please machine insert seat in accordance to the drawing.

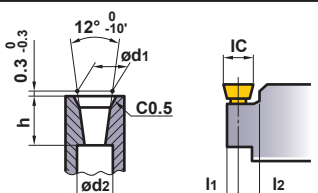
Insert Seat Dimensions	Insert Diameter IC	Dimensions (mm)					Taper Diameter
		h	d1	d2	l1	l2	
	5	4	2.5	1.9	1.85	3.2	1.5
	6	4	3.5	2.9	2.35	3.7	2.5
	7	6	3.5	2.5	2.75	4.3	2.1
	8	6	4.5	3.5	3.25	4.8	3.1
	10	7.5	5.5	4.2	4.15	5.9	3.8
	12	7.5	7.5	6.2	5.15	6.9	5.8