

Single Action Type

Double Clamp Series

New Clamp Bridge

Simple and highly rigid clamping

- A simple, secure clamping system ensures stable machining.
- New holders for VN type 35° rhombic inserts. Series expansion.
- New design clamp bridge for ultra clamping rigidity and improved chip evacuation.



Single Action Type Double Clamp Series

Features

Single action type double clamp system

- Newly developed highly rigid clamping system.
- Easy and secure insert retention.
- World class cutting edge indexing accuracy.

New optimized clamp bridge

The clamp bridge features a new geometry that is optimized for promoting good chip flow while maintaining tool rigidity. This has been achieved by using CAE design analysis technology to avoid chip packing problems. This new bridge type is also compatible with both right and left hand tool holders.



Special surface treatment

The body and clamp bridge has been treated with a special surface coating for higher corrosion and abrasion resistance.

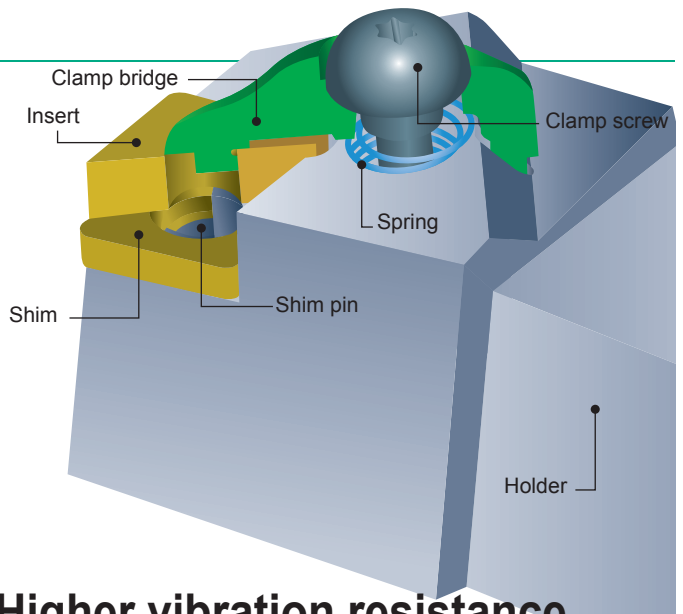

Higher vibration resistance and chip discharge properties

The dimple boring bar features excellent vibration resistance properties and through coolant holes for better chip discharge. In addition, a scale for easy overhang length setting is etched on the body.

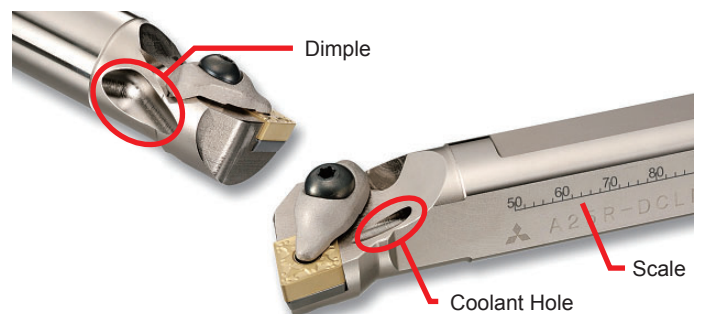





Double-ended torx hole clamp screw

Equally sized torx holes are provided on both ends of the clamp screw, making it easy to attach and remove the insert even when an inverted holder is used, thus ensuring rapid insert indexing and secure clamping.

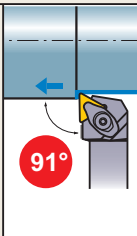
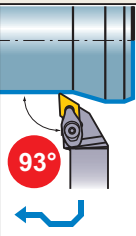
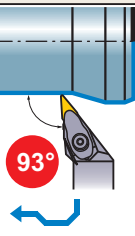
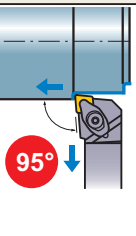
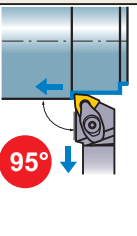
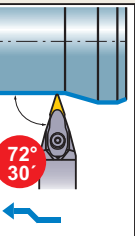
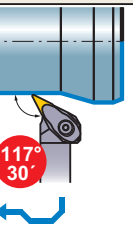

A wide selection of tool holders

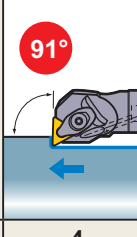
Mitsubishi's Double Clamp series. 13 types, 84 items

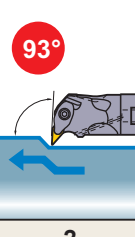
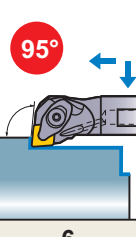
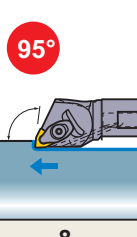
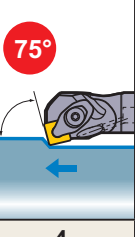
	Shape	Tool holder geometry							
External turning		Type							
		No. of items	6	14	4	12	12	2	4
Boring		Type							—
		No. of items	4	6	2	6	8	4	—

Cutting Performance

Clamping Rigidity

Higher fracture resistance during interrupted cutting!

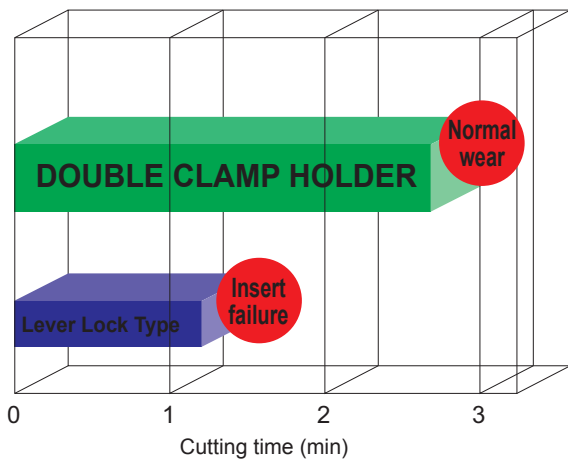

Accurate Cutting Edge Positioning

Precise cutting performance!

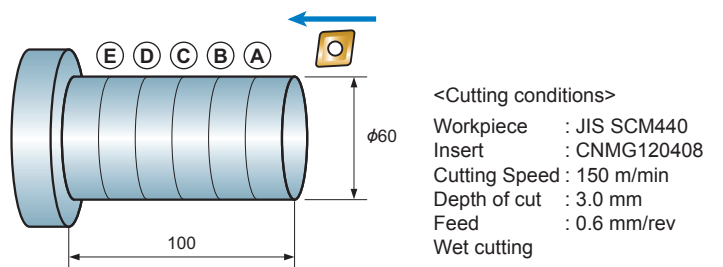
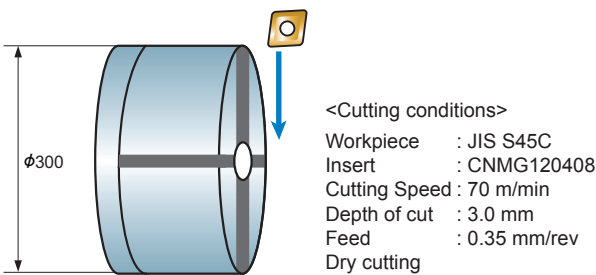
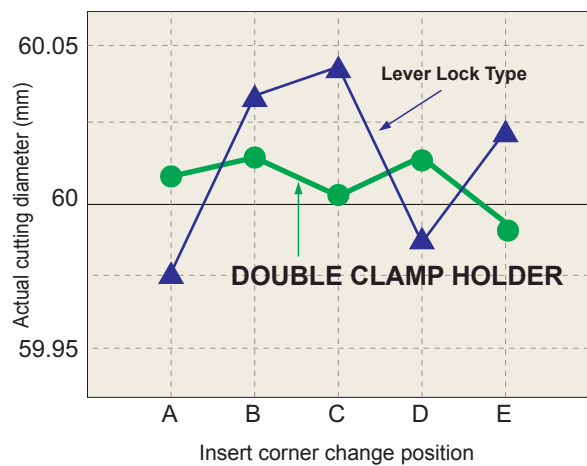

DOUBLE CLAMP HOLDER

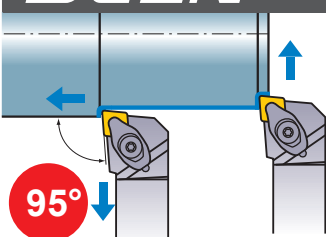





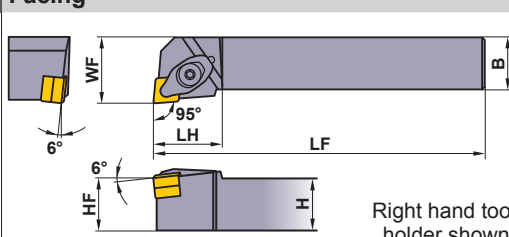









95°

DCLN External turning, *DOUBLE CLAMP type*
Facing



Right hand tool holder shown.

Finish	Light	Medium	Medium
FH  (12)	LP  (12)	MP  (12)	MK  (12)
Medium	Medium to Rough	Stainless	CBN
Standard  (09,12)	RP  (12)	MS  (12)	 (12)

Order Number	Stock		Insert Number	Dimensions (mm)							 *2     *1 					
	R	L		H	B	LF	LH	HF	WF	Shim	Shim Pin	Clamp Bridge	Spring	Clamp Screw	Wrench	
DCLNR/L1616H09	●	●	CNMG	09T3	16	16	100	25	16	20	LLSCN3T3 (LLSCN33)	LLP23	DCK2211	DCS2	DC0520T	TKY15F
DCLNR/L2020K09	●	●		09T3	20	20	125	25	20	25	LLSCN3T3 (LLSCN33)	LLP23	DCK2211	DCS2	DC0520T	TKY15F
DCLNR/L2525M09	●	●		09T3	25	25	150	25	25	32	LLSCN3T3 (LLSCN33)	LLP23	DCK2211	DCS2	DC0520T	TKY15F
DCLNR/L2020K12	●	●	CNMA	1204	20	20	125	29	20	25	LLSCN42	LLP14	DCK2613	DCS1	DC0621T	TKY20F
DCLNR/L2525M12	●	●	CNMG	1204	25	25	150	29	25	32	LLSCN42	LLP14	DCK2613	DCS1	DC0621T	TKY20F
DCLNR/L2525M12	●	●	CNMM	1204	25	25	150	29	25	32	LLSCN42	LLP14	DCK2613	DCS1	DC0621T	TKY20F
DCLNR/L3225P12	●	●	CNGG	1204	32	25	170	29	32	32	LLSCN42	LLP14	DCK2613	DCS1	DC0621T	TKY20F

*1 Clamp Torque (N · m) : DC0520T=3.5, DC0621T=5.0

*2 Please use shim no. LLSCN33 with 3.18mm thick inserts. When using 3.18mm thick inserts, shim should be ordered separately.

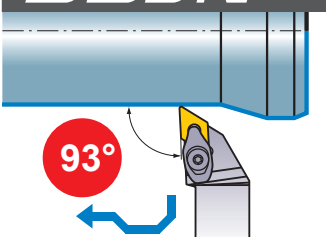





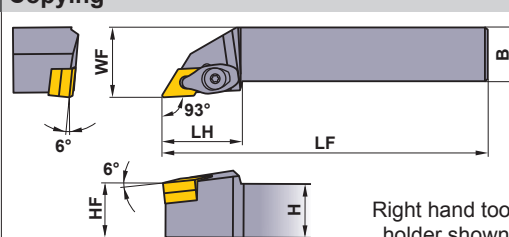









93°

DDJN External turning, *DOUBLE CLAMP type*
Copying



Right hand tool holder shown.

Finish	Light	Medium	Medium
FH  (15)	LP  (15)	MP  (15)	MK  (15)
Medium to Rough	Stainless	G Class	CBN
RP  (15)	MS  (15)	R/L  (15)	 (15)

Order Number	Stock		Insert Number	Dimensions (mm)							 *2     *1 					
	R	L		H	B	LF	LH	HF	WF	Shim	Shim Pin	Clamp Bridge	Spring	Clamp Screw	Wrench	
DDJNR/L1616H11	●	●	DNMG DNMX	1104	16	16	100	28	16	20	LLSDN32	LLP23	DCK2211	DCS2	DC0520T	TKY15F
DDJNR/L2020K11	●	●		1104	20	20	125	28	20	25	LLSDN32	LLP23	DCK2211	DCS2	DC0520T	TKY15F
DDJNR/L2525M11	●	●		1104	25	25	150	28	25	32	LLSDN32	LLP23	DCK2211	DCS2	DC0520T	TKY15F
DDJNR/L3225P11	●	●		1104	32	25	170	28	32	32	LLSDN32	LLP23	DCK2211	DCS2	DC0520T	TKY15F
DDJNR/L2020K15	●	●	DNMA	1504	20	20	125	37	20	25	LLSDN43 (LLSDN42)	LLP24	DCK2613	DCS1	DC0621T	TKY20F
DDJNR/L2525M15	●	●	DNMG	1504	25	25	150	37	25	32	LLSDN43 (LLSDN42)	LLP24	DCK2613	DCS1	DC0621T	TKY20F
DDJNR/L2525M15	●	●	DNMX	1504	25	25	150	37	25	32	LLSDN43 (LLSDN42)	LLP24	DCK2613	DCS1	DC0621T	TKY20F
DDJNR/L3225P15	●	●	DNGA DNMG	1504	32	25	170	37	32	32	LLSDN43 (LLSDN42)	LLP24	DCK2613	DCS1	DC0621T	TKY20F

*1 Clamp Torque (N · m) : DC0520T=3.5, DC0621T=5.0

*2 Please use shim no. LLSDN42 with 6.35mm thick inserts. When using 6.35mm thick inserts, shim should be ordered separately.

RECOMMENDED CUTTING CONDITIONS

Work Material	Cutting Mode	Breaker	Grade	Cutting Speed (m/min)
P Mild Steel (≤180HB)	Finish	FS	NX2525	260-370
	Light	SH	NX3035	235-335
	Medium	MS	UE6110	260-440
Carbon Steel Alloy Steel (180HB-280HB)	Finish	FH	NX3035	200-280
	Light	SH	UE6110	210-355
	Medium	MP	UE6110	190-325

Work Material	Cutting Mode	Breaker	Grade	Cutting Speed (m/min)
M Stainless Steel (≤200HB)	Finish	FH	US735	105-200
	Light	SH	US735	95-185
	Medium	MS	US735	85-165
K Gray Cast Iron (≤350MPa)	Light	MA	UC5115	160-295
	Medium	Standard	UC5115	160-295

(Note 1) The insert photos are only examples. The letters refer to the chip breaker and the dimension refers to the inscribed circle.

(Note 2) The new type clamp bridge and clamp screw can be used on conventional Double Clamp holders.

For details, refer to the cross reference table on page 10.

● : Inventory maintained in Japan.

Order Number		Stock		Insert Number	Dimensions (mm)							Accessories					
		R	L		H	B	LF	LH	HF	WF	Shim	Shim Pin	Clamp Bridge	Spring	Clamp Screw	Wrench	
DTGNR/L1616H16	●●	●●	TNMA	1604	16	16	100	25	16	20	LLSTN32 (LLSTN33)	LLP23	DCK2211	DCS2	DC0520T	TKY15F	
DTGNR/L2020K16	●●	●●	TNMG	1604	20	20	125	25	20	25	LLSTN32 (LLSTN33)	LLP23	DCK2211	DCS2	DC0520T	TKY15F	
DTGNR/L2525M16	●●	●●	TNMM	1604	25	25	150	25	25	32	LLSTN32 (LLSTN33)	LLP23	DCK2211	DCS2	DC0520T	TKY15F	

*1 Clamp Torque (N • m) : DC0520T=3.5

*2 Please use shim no. LLSTN33 with 3.18mm thick inserts. When using 3.18mm thick inserts, shim should be ordered separately.

Order Number		Stock		Insert Number	Dimensions (mm)							Accessories					
		R	L		H	B	LF	LH	HF	WF	Shim	Shim Pin	Clamp Bridge	Spring	Clamp Screw	Wrench	
DWLNR/L1616H06	●●	●●	WNMG	06T3	16	16	100	25	16	20	LLSWN3T3 (LLSWN32)	LLP23	DCK2211	DCS2	DC0520T	TKY15F	
DWLNR/L2020K06	●●	●●		06T3	20	20	125	25	20	25	LLSWN3T3 (LLSWN32)	LLP23	DCK2211	DCS2	DC0520T	TKY15F	
DWLNR/L2525M06	●●	●●		06T3	25	25	150	25	25	32	LLSWN3T3 (LLSWN32)	LLP23	DCK2211	DCS2	DC0520T	TKY15F	
DWLNR/L2020K08	●●	●●	WNMA WNMG	0804	20	20	125	31	20	25	LLSWN42	LLP14	DCK2613	DCS1	DC0621T	TKY20F	
DWLNR/L2525M08	●●	●●		0804	25	25	150	31	25	32	LLSWN42	LLP14	DCK2613	DCS1	DC0621T	TKY20F	
DWLNR/L3225P08	●●	●●		0804	32	25	170	31	32	32	LLSWN42	LLP14	DCK2613	DCS1	DC0621T	TKY20F	

*1 Clamp Torque (N • m) : DC0520T=3.5, DC0621T=5.0

*2 Please use shim no. LLSWN32 with 4.76mm thick inserts. When using 4.76mm thick inserts, shim should be ordered separately.

DOUBLE CLAMP HOLDER

DVJN

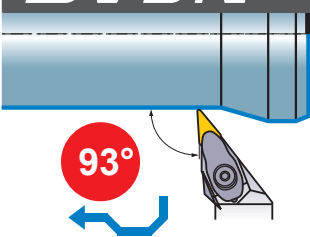





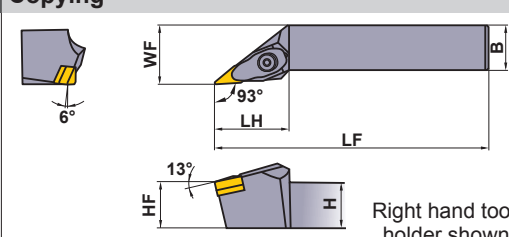







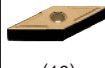

93°

External turning, DOUBLE CLAMP type
Copying



Right hand tool holder shown.

Finish	Light	Medium	Medium
FH	LP	MP	MK
			
(16)	(16)	(16)	(16)
Medium	Stainless	G Class	CBN
Standard	MS	R/L	
			
(16)	(16)	(16)	(16)

Order Number	Stock		Insert Number	Dimensions (mm)							     					
	R	L		H	B	LF	LH	HF	WF	Shim	Shim Pin	Clamp Bridge	Spring	Clamp Screw	Wrench	
DVJNR/L2020K16	●	●	VNMG VNGA VNGG	1604	20	20	125	41	20	25	DCSVN32	LLP13	DCK3113	DCS2	DC0520T	TKY15F
DVJNR/L2525M16	●	●	VNMG VNGA VNGG	1604	25	25	150	41	25	32	DCSVN32	LLP13	DCK3113	DCS2	DC0520T	TKY15F

* Clamp Torque (N · m) : DC0520T=3.5

DVPN

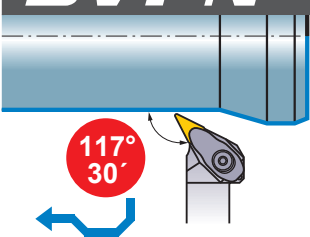





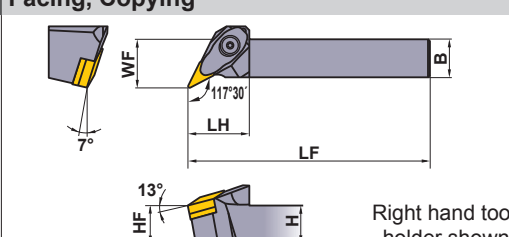





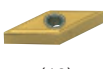

117°
30'

Facing, Copying
DOUBLE CLAMP type



Right hand tool holder shown.

Finish	Light	Medium	Medium
FH	LP	MP	MK
			
(16)	(16)	(16)	(16)
Medium	Stainless	G Class	CBN
Standard	MS	R/L	
			
(16)	(16)	(16)	(16)

Order Number	Stock		Insert Number	Dimensions (mm)							     					
	R	L		H	B	LF	LH	HF	WF	Shim	Shim Pin	Clamp Bridge	Spring	Clamp Screw	Wrench	
DVPNR/L2020K16	●	●	VNMG VNGA VNGG	1604	20	20	125	32	20	25	DCSVN32	LLP13	DCK3113	DCS2	DC0520T	TKY15F
DVPNR/L2525M16	●	●	VNMG VNGA VNGG	1604	25	25	150	32	25	32	DCSVN32	LLP13	DCK3113	DCS2	DC0520T	TKY15F

* Clamp Torque (N · m) : DC0520T=3.5

RECOMMENDED CUTTING CONDITIONS

Work Material	Cutting Mode	Breaker	Grade	Cutting Speed (m/min)	Work Material	Cutting Mode	Breaker	Grade	Cutting Speed (m/min)
P Mild Steel (≤180HB)	Finish	FS	NX2525	260-370	M Stainless Steel (≤200HB)	Finish	FH	US735	105-200
	Light	SH	NX3035	235-335		Light	SH	US735	95-185
	Medium	MS	UE6110	260-440		Medium	MS	US735	85-165
Carbon Steel Alloy Steel (180HB-280HB)	Finish	FH	NX3035	200-280	K Gray Cast Iron (≤350MPa)	Light	MA	UC5115	160-295
	Light	SH	UE6110	210-355		Medium	Standard	UC5115	160-295
	Medium	MP	UE6110	190-325					

(Note) The insert photos are only examples. The letters refer to the chip breaker and the dimension refers to the inscribed circle.

● : Inventory maintained in Japan.

DVNN		External turning, DOUBLE CLAMP type Copying							Finish		Light	Medium	Medium		
									FH	LP	MP	MK			
									 (16)	 (16)	 (16)	 (16)			
									Medium	Stainless	G Class	CBN			
									Standard	MS	R/L				
									(16)	(16)	(16)	(16)			
Order Number	Stock	Insert Number	Dimensions (mm)												
			H	B	LF	LH	HF	WF	Shim	Shim Pin	Clamp Bridge	Spring	Clamp Screw	Wrench	
DVNN2020K16	●	VNMA VNMG VNGA VNGG	1604	20	20	125	44	20	10	DCSVN32	LLP13	DCK3113	DCS2	DC0520T	TKY15F
DVNN2525M16	●	VNMA VNMG VNGA VNGG	1604	25	25	150	44	25	12.5	DCSVN32	LLP13	DCK3113	DCS2	DC0520T	TKY15F

* Clamp Torque (N · m) : DC0520T=3.5

Single Action Type

DOUBLE CLAMP DIMPLE BAR

DCLN

With coolant hole CN○inserts

95°

Right hand tool holder shown.

Order Number	Stock		Insert Number	Dimensions(mm)								Accessories						
	R	L		DCON	LF	LDRED	WF	H	GAMF	DMIN	RE	Shim	Shim Pin	Clamp Bridge	Spring	Clamp Screw *	Wrench	
A25R-DCLNR/L12	●	●	CNMA CNMG CNMM	1204	25	200	40	17	23	11°	32	0.8	LLSCP42	LLP14	DCK2613	DCS1	DC0621T	TKY20F
A32S-DCLNR/L12	●	●	CNMA CNMG CNMM	1204	32	250	50	22	30	13°	40	0.8	LLSCP42	LLP14	DCK2613	DCS1	DC0621T	TKY20F
A40T-DCLNR/L12	●	●	CNMG CNGG	1204	40	300	63	27	37	10°	50	0.8	LLSCP42	LLP14	DCK2613	DCS1	DC0621T	TKY20F

* Clamp Torque (N · m) : DC0621T=5.0

DDUN

With coolant hole DN○inserts

93°

Right hand tool holder shown.

Order Number	Stock		Insert Number	Dimensions(mm)								Accessories						
	R	L		DCON	LF	LDRED	WF	H	GAMF	DMIN	RE	Shim	Shim Pin	Clamp Bridge	Spring	Clamp Screw *	Wrench	
A25R-DDUNR/L15	●	●	DNMA DNMG DNMX	1504	25	200	40	17	23	13°	35	0.8	LLSDP42	LLP14	DCK2613	DCS1	DC0621T	TKY20F
A32S-DDUNR/L15	●	●	DNMA DNMG DNMX	1504	32	250	50	22	30	13°	40	0.8	LLSDP42	LLP14	DCK2613	DCS1	DC0621T	TKY20F
A40T-DDUNR/L15	●	●	DNMG DNMA DNMX DNMG DNMX	1504	40	300	63	27	37	10°	50	0.8	LLSDP42	LLP14	DCK2613	DCS1	DC0621T	TKY20F

* Clamp Torque (N · m) : DC0621T=5.0

RECOMMENDED CUTTING CONDITIONS

Work Material	Hardness	Cutting Mode	l/d ≤ 3			l/d = 3-4		
			Cutting Speed (m/min)	Feed (mm/rev)	Depth of Cut (mm)	Cutting Speed (m/min)	Feed (mm/rev)	Depth of Cut (mm)
P Carbon Steel Alloy Steel	180-350HB	Medium	110 (80-140)	0.25 (0.1-0.4)	-5.0	110 (80-140)	0.2 (0.1-0.3)	-4.0
M Stainless Steel	≤200HB	Medium	80 (60-100)	0.2 (0.1-0.3)	-4.0	70 (50-100)	0.15 (0.1-0.25)	-3.0
K Gray Cast Iron	Tensile Strength ≤350MPa	Medium	80 (60-100)	0.25 (0.1-0.4)	-5.0	80 (60-100)	0.2 (0.1-0.3)	-4.0

(Note 1) The insert photos are only examples. The letters refer to the chip breaker and the dimension refers to the inscribed circle.

(Note 2) When using insert with right and left hand chip breaker, please use left hand insert for right hand holder and right hand insert for left hand holder.

● : Inventory maintained in Japan.

Order Number		Stock		Insert Number	Dimensions(mm)							Accessories						
		R	L		DCON	LF	LDRED	WF	H	GAMF	DMIN	RE	Shim	Shim Pin	Clamp Bridge	Spring	Clamp Screw	Wrench
A25R-DSKNR/L12	●	●	SNMA SNMG SNMM	1204	25	200	40	17	23	13°	32	0.8	LLSSP42	LLP14	DCK2613	DCS1	DC0621T	TKY20F
A32S-DSKNR/L12	●	●	SNGA SNGG	1204	32	250	50	22	30	13°	40	0.8	LLSSN42	LLP14	DCK2613	DCS1	DC0621T	TKY20F

* Clamp Torque (N • m) : DC0621T=5.0

Order Number		Stock		Insert Number	Dimensions(mm)							Accessories						
		R	L		DCON	LF	LDRED	WF	H	GAMF	DMIN	RE	Shim	Shim Pin	Clamp Bridge	Spring	Clamp Screw	Wrench
A25R-DTFNR/L16	●	●	TNMA TNMG TNMM	1604	25	200	40	17	23	13°	32	0.8	LLSTP32	LLP23	DCK2211	DCS2	DC0520T	TKY15F
A32S-DTFNR/L16	●	●	TNGA TNGG	1604	32	250	50	22	30	13°	40	0.8	LLSTN32	LLP23	DCK2211	DCS2	DC0520T	TKY15F

* Clamp Torque (N • m) : DC0520T=3.5

(Note 1) The insert photos are only examples. The letters refer to the chip breaker and the dimension refers to the inscribed circle.
 (Note 2) When using insert with right and left hand chip breaker, please use left hand insert for right hand holder and right hand insert for left hand holder.

Single Action Type

DOUBLE CLAMP DIMPLE BAR

Order Number		Stock		Insert Number		Dimensions(mm)							Tools							
						DCON	LF	LDRED	WF	H	GAMF	DMIN	RE	Shim	Shim Pin	Clamp Bridge	Spring	Clamp Screw *	Wrench	
A40T-DVUNR/L16		●	●	VNMA	VNMA	1604	40	300	63	27	37	9°	50	0.8	DCSVN32	LLP13	DCK3113	DCS2	DC0520T	TKY15F

* Clamp Torque (N · m) : DC0520T=3.5

Order Number		Stock		Insert Number		Dimensions(mm)							Tools							
						DCON	LF	LDRED	WF	H	GAMF	DMIN	RE	Shim	Shim Pin	Clamp Bridge	Spring	Clamp Screw *	Wrench	
A25R-DWLNR/L06		●	●	WNMG	WNMG	0604	25	200	40	17	23	13°	35	0.8	LLSWP32	LLP23	DCK2211	DCS2	DC0520T	TKY15F
A25R-DWLNR/L08		●	●	WNMG	WNMG	0804	25	200	40	17	23	13°	35	0.8	LLSWP42	LLP14	DCK2613	DCS1	DC0621T	TKY20F
A32S-DWLNR/L08		●	●	VNMA	VNMA	0804	32	250	50	22	30	13°	40	0.8	LLSWN42	LLP14	DCK2613	DCS1	DC0621T	TKY20F
A40T-DWLNR/L08		●	●	VNMA	VNMA	0804	40	300	63	27	37	10°	50	0.8	LLSWN42	LLP14	DCK2613	DCS1	DC0621T	TKY20F

* Clamp Torque (N · m) : DC0520T=3.5, DC0621T=5.0

RECOMMENDED CUTTING CONDITIONS

Work Material	Hardness	Cutting Mode	l/d ≤ 3			l/d = 3-4		
			Cutting Speed (m/min)	Feed (mm/rev)	Depth of Cut (mm)	Cutting Speed (m/min)	Feed (mm/rev)	Depth of Cut (mm)
P Carbon Steel Alloy Steel	180-350HB	Medium	110 (80-140)	0.25 (0.1-0.4)	-5.0	110 (80-140)	0.2 (0.1-0.3)	-4.0
M Stainless Steel	≤200HB	Medium	80 (60-100)	0.2 (0.1-0.3)	-4.0	70 (50-100)	0.15 (0.1-0.25)	-3.0
K Gray Cast Iron	Tensile Strength ≤350MPa	Medium	80 (60-100)	0.25 (0.1-0.4)	-5.0	80 (60-100)	0.2 (0.1-0.3)	-4.0

(Note 1) The insert photos are only examples. The letters refer to the chip breaker and the dimension refers to the inscribed circle.

(Note 2) When using insert with right and left hand chip breaker, please use left hand insert for right hand holder and right hand insert for left hand holder.

● : Inventory maintained in Japan.

Cross reference table for old and new parts

Order Number	Shim	Shim Pin	Spring	Clamp Bridge		Clamp Screw		Wrench		Punch
				Old Number	New Number	Old Number	New Number	Old Number	New Number	
DCLNR/L1616H09	LLSCN3T3 (LLSCN33)	LLP23	DCS2	DCK11R/L	DCK2211	DCCS085	DC0520T	HKY30R	TKY15F	LLH3
DCLNR/L 2020K09	LLSCN3T3 (LLSCN33)	LLP23	DCS2	DCK11R/L	DCK2211	DCCS085	DC0520T	HKY30R	TKY15F	LLH3
DCLNR/L 2525M09	LLSCN3T3 (LLSCN33)	LLP23	DCS2	DCK11R/L	DCK2211	DCCS085	DC0520T	HKY30R	TKY15F	LLH3
DCLNR/L2020K12	LLSCN42	LLP14	DCS1	DCK14R/L	DCK2613	DCBS106	DC0621T	HKY40R	TKY20F	LLH4
DCLNR/L 2525M12	LLSCN42	LLP14	DCS1	DCK14R/L	DCK2613	DCBS106	DC0621T	HKY40R	TKY20F	LLH4
DCLNR/L 3225P12	LLSCN42	LLP14	DCS1	DCK14R/L	DCK2613	DCBS106	DC0621T	HKY40R	TKY20F	LLH4
DDJNR/L1616H11	LLSDN32	LLP23	DCS2	DCK11R/L	DCK2211	DCCS085	DC0520T	HKY30R	TKY15F	LLH3
DDJNR/L 2020K11	LLSDN32	LLP23	DCS2	DCK11R/L	DCK2211	DCCS085	DC0520T	HKY30R	TKY15F	LLH3
DDJNR/L 2525M11	LLSDN32	LLP23	DCS2	DCK11R/L	DCK2211	DCCS085	DC0520T	HKY30R	TKY15F	LLH3
DDJNR/L 3225P11	LLSDN32	LLP23	DCS2	DCK11R/L	DCK2211	DCCS085	DC0520T	HKY30R	TKY15F	LLH3
DDJNR/L2020K15	LLSDN43 (LLSDN42)	LLP24 (LLP14)	DCS1	DCK14R/L	DCK2613	DCBS106	DC0621T	HKY40R	TKY20F	LLH4
DDJNR/L 2525M15	LLSDN43 (LLSDN42)	LLP24 (LLP14)	DCS1	DCK14R/L	DCK2613	DCBS106	DC0621T	HKY40R	TKY20F	LLH4
DDJNR/L 3225P15	LLSDN43 (LLSDN42)	LLP24 (LLP14)	DCS1	DCK14R/L	DCK2613	DCBS106	DC0621T	HKY40R	TKY20F </td <td>LLH4</td>	LLH4
DTGNR/L1616H16	LLSTN32 (LLSTN33)	LLP23	DCS2	DCK11R/L	DCK2211	DCCS085	DC0520T	HKY30R	TKY15F	LLH3
DTGNR/L2020K16	LLSTN32 (LLSTN33)	LLP23	DCS2	DCK11R/L	DCK2211	DCCS085	DC0520T	HKY30R	TKY15F	LLH3
DTGNR/L 2525M16	LLSTN32 (LLSTN33)	LLP23	DCS2	DCK11R/L	DCK2211	DCCS085	DC0520T	HKY30R	TKY15F	LLH3
DWLNR/L1616H06	LLSWN3T3 (LLSWN32)	LLP23	DCS2	DCK11R/L	DCK2211	DCCS085	DC0520T	HKY30R	TKY15F	LLH3
DWLNR/L2020K06	LLSWN3T3 (LLSWN32)	LLP23	DCS2	DCK11R/L	DCK2211	DCCS085	DC0520T	HKY30R	TKY15F	LLH3
DWLNR/L2525M06	LLSWN3T3 (LLSWN32)	LLP23	DCS2	DCK11R/L	DCK2211	DCCS085	DC0520T	HKY30R	TKY15F	LLH3
DWLNR/L2020K08	LLSWN42	LLP14	DCS1	DCK14R/L	DCK2613	DCBS106	DC0621T	HKY40R	TKY20F	LLH4
DWLNR/L2525M08	LLSWN42	LLP14	DCS1	DCK14R/L	DCK2613	DCBS106	DC0621T	HKY40R	TKY20F	LLH4
DWLNR/L3225P08	LLSWN42	LLP14	DCS1	DCK14R/L	DCK2613	DCBS106	DC0621T	HKY40R	TKY20F	LLH4

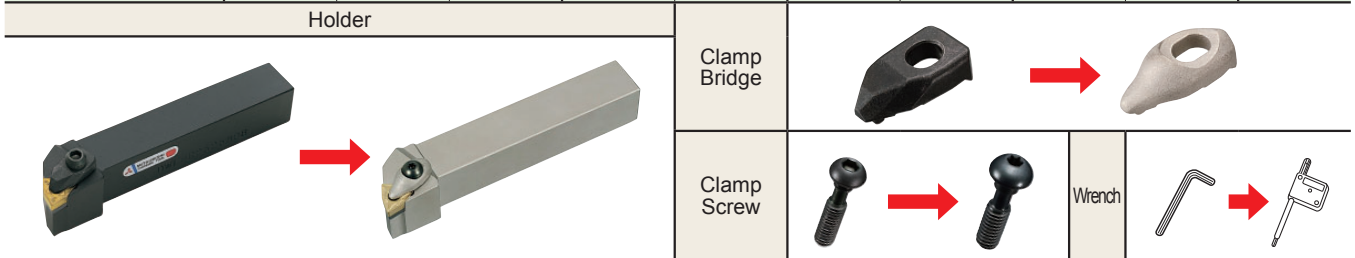

Operational Guidance

- When indexing or replacing an insert, check there is clearance between the protruding section of the clamp and the insert, as shown in the figure below. → Guide: Turn the clamp screw 2-3 rotations from the fully clamped state to ensure clearance.
- When clamping the insert, be sure to use the wrench provided. Over tightening may cause damage to the clamp bridge and the torx holes of the clamp screw. (The appropriate tightening torque is 5.0Nm for a TKY20F wrench size; 3.5Nm for a TKY15F type.)

Unclamped state

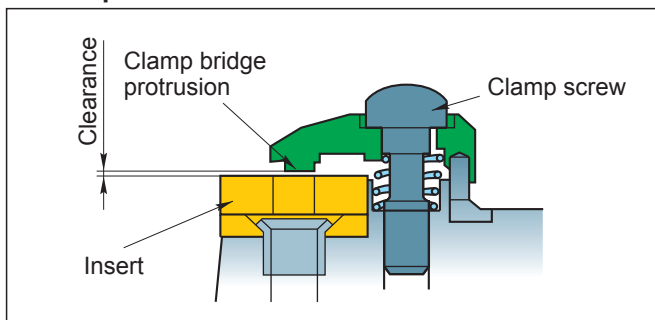

Clamped state

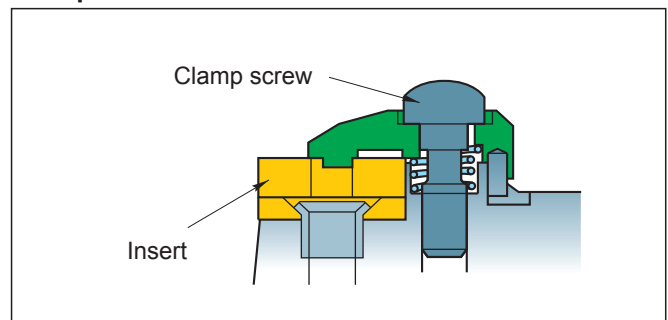

- If chips interfere or wrap around the clamp screw, the selected insert breaker may not be suitable. In this case, a review of the insert breaker is recommended as this may affect the surface finish accuracy of the workpiece.

Application Examples

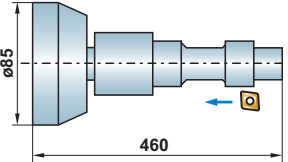
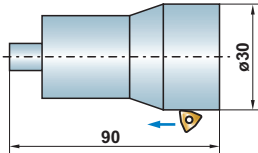
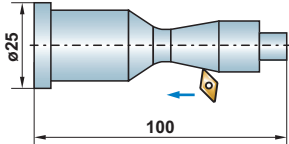
Tool	DCLNL2525M12	DWLN2020K08	DVJNR2525M16	
Insert	CNMG120408-MA	WNMG080408-SA	VNMG160408-MV	
Insert Grade	P10 CVD	P10 CVD	UE6020	
Workpiece	JIS S53C 	JIS S45C 	JIS SCM440 	
Cutting Conditions	Cutting Speed (m/min)	140 – 150	150 – 222	175
	Feed (mm/rev)	0.25	0.15 – 0.4	0.4
	Depth of Cut (mm)	1.0 – 3.5	1.0 – 2.0	1.0
Cutting mode	Water soluble	Water soluble	Water soluble	
Results	Abnormal damage to the insert is unlikely to occur during machining because mis-clamping can easily be avoided compared to when using conventional products.	Dimensional control becomes easier due to a higher cutting edge positioning accuracy.	Higher clamping rigidity of the insert and a 20% increase in the number of components machined.	

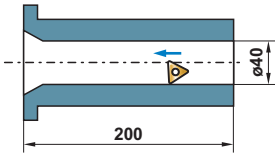
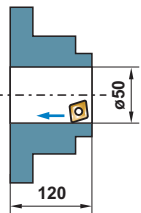
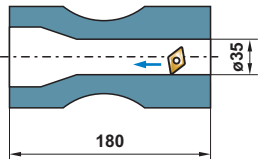
Tool	A32S-DTFNR16	A32S-DCLNR12	A25R-DDUNR15	
Insert	TNMG160404-MS	CNMG120408-MS	DNMG150408-MA	
Insert Grade	US7020	VP15TF	UE6020	
Workpiece	JIS S45C 	JIS SUS316 	JIS SCM440 	
Cutting Conditions	Cutting Speed (m/min)	150	130	150
	Feed (mm/rev)	0.4	0.2	0.25
	Depth of Cut (mm)	1.0	2.0	1.5
Cutting mode	Water soluble	Water soluble	Water soluble	
Results	Excellent machining with no vibration even when using a long overhang of $l/d = 5.5$.	Double tool life achieved with no vibration when compared to conventional products.	Prolonged tool life with no vibration even when using an overhang 2 times longer than normal.	

For Your Safety

●Don't handle inserts and chips without gloves. ●Please machine within the recommended application range and exchange expired tools with new ones in advance of breakage. ●Please use safety covers and wear safety glasses. ●When using compounded cutting oils, please take fire precautions. ●When using rotating tools, please make a trial run to check run-out, vibration and abnormal sounds etc. ●Grinding or heating of cutting tools produces dust and mist. Inhaling large amount of dust or contacting with eyes and skins may harm your body.

MITSUBISHI MATERIALS CORPORATION

MITSUBISHI MATERIALS CORPORATION

Overseas Sales Dept, Asian Region

KFC bldg., 8F, 1-6-1 Yokoami, Sumida-ku, Tokyo 130-0015, Japan
 TEL +81-3-5819-8771 FAX +81-3-5819-8774

Overseas Sales Dept, European & American Region

KFC bldg., 8F, 1-6-1 Yokoami, Sumida-ku, Tokyo 130-0015, Japan
 TEL +81-3-5819-8772 FAX +81-3-5819-8774

URL : <http://www.mitsubishicarbide.com>
 (Tools specifications subject to change without notice.)